

*California State Polytechnic University, Pomona  
Mechanical Engineering Department  
ME 220L Strength of Materials  
Laboratory Manual*

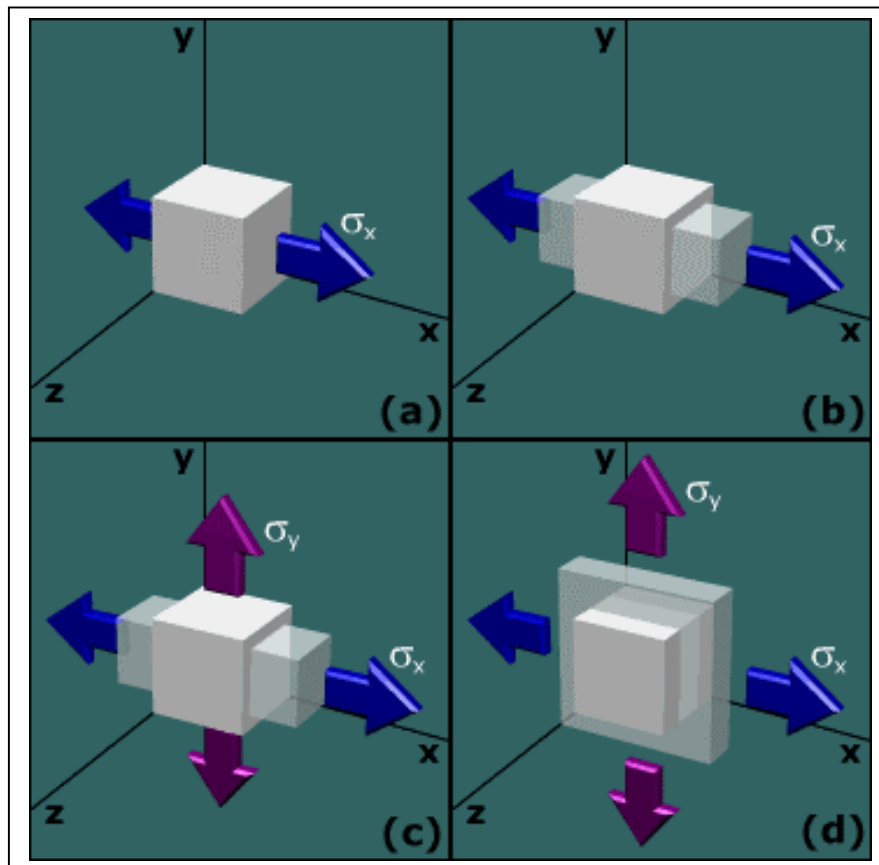

*Prepared by C.M. Stover, P.E.  
Mechanical Engineering Department  
California State Polytechnic University, Pomona*

## **ME 220L Laboratory Manual Table of Contents**

<b>Introduction</b>	<b>3</b>
<b>Report Format</b>	<b>5</b>
<b>Significant Figures</b>	<b>7</b>
<b>Electrical Resistance Strain Gages</b>	<b>9</b>
<b>Tensile Testing Overview</b>	<b>14</b>
<b>Experiment A – Tension Test</b>	<b>16</b>
<b>Torsion Testing Overview</b>	<b>19</b>
<b>Experiment B - Torsion Experiment</b>	<b>21</b>
<b>Beam Experiment Overview</b>	<b>22</b>
<b>Experiment C - Cantilever Beam Experiment</b>	<b>23</b>
<b>Experiment D - Simply Supported Beam Experiment</b>	<b>24</b>
<b>Experiment E - Combined Loading Experiment</b>	<b>25</b>
<b>Column Buckling Overview</b>	<b>27</b>
<b>Experiment F - Column Buckling Experiment</b>	<b>29</b>
<b>Appendix A Quick Reference – Selected Materials</b>	<b>30</b>
<b>Appendix B Glossary of Mechanical Properties and Tests</b>	<b>31</b>
<b>Appendix C References</b>	<b>54</b>

## ***Introduction***

One of the principle concerns of an engineer is the analysis of materials used in structural applications. The term structure refers to any design that utilizes materials that support loads and keeps deformation within acceptable limits. Designing machines, structures, and vehicles, which are reliable as well as safe and cost effective, requires a proper knowledge of engineering as well as material selection.

Elementary mechanics of materials or strength of materials is the physical science that looks at the reaction of a body to movement and deformation due to mechanical, thermal, or other loads. The basis of virtually all mechanical design lies in how the material reacts to outside forces. Mechanics is the core of engineering analysis and is one of the oldest of the physical sciences. An in-depth understanding of material properties as well as how certain materials react to outside stimulus is paramount to an engineering education.

The basis of structural design is simply to design a component where the stress does not exceed the strength of the material, causing failure. These failures may include additional complexities such as stresses that act in more than one direction, where the state of stress may be biaxial or triaxial. Failure may also be due to components or materials containing flaws and / or cracks that will propagate failure. Still other failure mechanisms may involve stresses applied for extended periods of time causing Creep, or stresses that are repeatedly applied and removed leading to cyclical type failure.

Material failures may be time dependant such as creep or fatigue failure due to cyclical loading, or failures may be time independent where static loading causes rapid fracturing of the material. Time independent fracture or failure due to static loading may be brittle, where very little deformation in the material takes place, or ductile, where significant plastic deformation takes place before failure.

Elastic and Plastic deformations are quantified in terms of normal and shear strain in elementary strength of materials studies. The effects of strains in a component are due to deformations such as bending, twisting or stretching. Some members rely on deformations to function, such as a spring, but an excessive amount causing permanent changes are typically avoided. Materials capable of sustaining large amounts of plastic deformation are said to behave in a ductile manner, those that fracture without much plastic deformation are said to behave in a brittle manner.

In this laboratory, students will have the opportunity to apply loads to various materials under different equilibrium conditions. The student will perform tests on materials in tension, torsion, bending, and buckling. These conditions and/or constraints are designed to reinforce classroom theory by having the student perform required tests, analyze subsequent data, and present the results in a professionally prepared report.

The machines and equipment used to determine experimental data include several universal testing machines, simply supported as well as cantilever beams with static weights and hangers, presses, and torsion equipment. Data will be collected using Dial indicators, extensometers, strain gages and strain indicator equipment, as well as load and strain readouts on the machinery and graphing capabilities to print relevant plots for analysis.

It is important to recognize that much of the testing performed in a typical mechanics lab involves a great deal of visual interpretation. Material behavior can be clearly observed during testing and for any type of destructive testing, fracture zone and material behavior observations are a key element to a clear and professional lab write up.

## ***Report Format***

The following example is what will be expected regarding the format and substance of the lab write-ups. Text should be in 3<sup>rd</sup> person passive voice, this is a technical write-up and should not be written in a personal or active voice.

(Do not hand in reports or graphs that are hand written or hand drawn. If you do not have a computer available, a computer account can be provided to you in order to access the computer labs)

### **MEMORANDUM**

*Date: (Date Submitted)*

*To: (Instructor...)*

*From: (Student.....)*

*Subject: (Experiment Performed)*

*Group Members: (Lab Partners)*

*Date Performed:*

*References: (Including the lab manual and any text/publication referenced during write-up) If any material is either paraphrased or directly quoted in the report, it must be properly referenced both within the text and cited using MLA style*

The write-up should include the following in this order: Objectives, Procedures, Results, Conclusions, Tables, Graphs, Sample Calculations, and Data Sheet(s). (Tables, Graphs, Sample Calculations and Data Sheet(s) should all be on separate pages).

**The objectives** of each experiment are described in the lab manual. Clear experimental objectives must be stated. If quoted or paraphrased from the lab manual, be sure to properly reference the information.

**The procedure** describes the conduct or “procedure” of the experiment indicating the significant equipment and/or instruments used.

**Results and Conclusions** of the experiment should be discussed. Important results should be summarized and compared to published values (numerical values may be cited here). Known or likely reasons should be stated to explain significant discrepancies and conclusions drawn from these results. The conclusions should also reflect back to the stated objectives. Discuss what was learned and whether or not the objectives were met.

**Tables** should include experimental values, published values (or theoretical), and their respective percent differences. These tables need to be a clear representation of experimental data as compared to published or theoretical values. At the bottom of the page containing the table, cite the reference in which the published values were obtained. Raw data tables used to generate plots and graphs should be at the back of the report with data sheets and other sources of experimental data.

**Graph(s)** must be prepared using a computer program. Select a scale to fill most of the coordinate area without crowding. Each scale should clearly state the name of the quantity, the units of measure, and a symbol (if any). A title block must be included and be explicit regarding what is shown on the graph. Included should be the name of the school and department, the data source, the name of the experimenter, and the date. When a plot is generated during an experiment, it is not only a visual representation of the engineering properties of the material being tested, it is also a tool used to calculate engineering data such as the modulus of elasticity, modulus of resilience, etc. Do not use a single point to calculate engineering values, utilize the portion of the experimental plot that will allow you to calculate the data required, such as the linear portion of a stress-strain plot to find the modulus of elasticity.

**Sample calculations** may or may not be necessary in a memo report depending on the policy of the particular company or facility involved. However, please include a sample calculation for each significant calculation made. A sample calculation should state the formula in general terms first. This is then followed by the insertion of the numbers into the formula to obtain the result (box or double underling the result). The numbers should be values from the experiment and appropriate units for each term should be included. Sample calculations are a separate item in the report, do not include them with any other information.

**The original data sheet(s)** is the official and legal record of an engineering test. It is an important document and must be well planned and executed. Data sheets must include the following: Test Name (title), Test Personnel (group members), Date, and Location of Test. The equipment and instruments used in the test should be identified (along with serial numbers and/or calibration dates if available). All data columns must be identified with the variable name, symbol, and units.

NEVER erase a data entry, simply strike a line through or cross out any erroneous entry or mistake so that this information is not lost.

There will be only ONE data sheet generated during experimentation per group.

## Significant Figures

Be extremely cautious in the use of significant figures, reporting a value with an unnecessary amount of significant figures may imply a resolution that is sometimes not attainable with the equipment being used. How important it is to watch your significant figures in any type of engineering or design work? Please read the following paragraph and think about the amount of significant figures the next time you collect, analyze and present data. (this particular incident actually happened in 1988)

A company had a new engineer design a piece of tooling to punch square holes in a computer housing incorporating 4 small lights. This was an engineering change that wasn't performed prior to the first run of parts, and the injection mold that created the housings had already been built and was running. The mold was removed and the required changes were made but there were already 3,000 molded parts that needed to be reworked before final assembly could be completed. The dollar amount and time involved was calculated and the tool, engineering time, and labor to punch the holes were assumed to cost much less than scrapping 3000 parts. The engineer designed a competent tool to accomplish the task and sent the drawings to the facilities in house machine shop to have built. The toolmaker in charge questioned the engineer on the tolerances called out but was assured by the engineer the calculations and tolerances were correct and the tooling needed to be built as soon as possible. What should have cost around \$1000 – \$1500 to manufacture turned out to be an \$18000 piece of tooling. Almost every dimension called out carried 4 significant figures. The units were in inches, which resulted in the dimensions needing to stay within 0.0001 in. or 1 ten thousandth of an inch. There was absolutely no need for this level of accuracy and man hours to manufacture this particular tool, but due to the engineers lack of knowledge of both the machining processes involved and the tolerance called out, the cost to the engineering department was astronomical and the time to build the tooling completely unnecessary .

### **The following are basic rules concerning significant figures:**

Any digit that is not zero is significant.

1234.56 has 6 significant figures

Zeros between non-zero digits are significant.

1002.5 has 5 significant figures

Zeros to the left of the first non-zero digit are not significant.

000456 has 3 significant figures

0.0056 has 2 significant figures

If the number is greater than one (1), then all zeros to the right of the decimal point are significant.

457.12 has 5 significant figures

400.00 has 5 significant figures

If the number is less than one, then only zeros that are at the end of the number and between non-zero digits are significant.

0.01020 has 4 significant figures

For numbers that do not contain decimal points, the trailing zeros may or may not be significant.

0.0010 has 2 significant figures

1.000 has 4 significant figures

NOTE: It is much easier to count and keep track of significant figures if the number is written in scientific notation.

### Use in calculations

Addition & Subtraction: The number of significant figures to the right of the decimal point in the final sum or difference is determined by the lowest number of significant figures to the right of the decimal point in any of the original numbers.

$6.2456 + 6.2 = 12.4456$  rounded to 12.4 note: 3 significant figures in answer

Multiplication & Division: The number of significant figures in the final product or quotient is determined by the original number that has the smallest number of significant figures.

$2.51 \times 2.30 = 5.773$  rounded to 5.77

$2.4 \times 0.000673 = 0.0016152$  rounded to 0.0016

### Rounding

1. Drop the digits that follow the last significant digit if the first digit is less than 5.

Round 1.61562 to 2 significant figures ANS: 1.6

2. If the first digit to be dropped is greater than five, increase the preceding digit by 1.

Round 1.61562 to 5 significant figures ANS: 1.6156

3. If the first digit to be dropped is five and there are non-zero digits following the five, increase the preceding digit by 1.

Round 1.61562 to 3 significant figures ANS: 1.62

Round 1.62500003 to 3 significant figures ANS: 1.63

4. If the first digit to be dropped is five and there are only zeros following the five, round to the even number.

Round 1.655000 to 3 significant figures ANS: 1.66

Round 1.625000 to 3 significant figures ANS: 1.62

## Electrical Resistance Strain Gages

A strain gage is a commonly used device for measuring strain. Most gages come in foil, semiconductor, or wire type configurations. A foil type gage is a thin piece of foil (0.0002 in.) and is constructed using a photoetching method, a wire type of gage is constructed of a thin wire (0.001 in), the semiconductor bonded strain gage is a wafer with the resistance element diffused into a substrate of silicon.

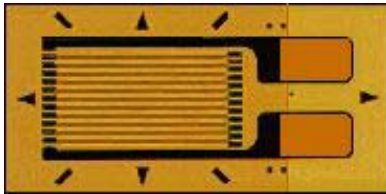

The wire or foil is generally bonded to a thin plastic and firmly glued to a surface. The gage is attached and oriented in a direction of interest in strain. As the body deforms or deflects, the gage deforms with the body and a change in electrical resistance occurs due to the wire or foil changing geometry during expansion or contraction. As in a wire gage, as the wire elongates, the corresponding cross section area changes depending on loading conditions. If a current is run through this wire, the change in diameter due to loading will cause a change in electrical resistance, this is the basis of the function of the gage, initially discovered by Lord Kelvin in 1856.

A single gage will only measure strain in one direction, but a cluster or rosette of gages allow measurements in multiple directions which will yield data to use in determining plane strain at a point from the true strain components  $\epsilon_x$ ,  $\epsilon_y$ ,  $\phi_{xy}$ .

The deformation of the body and the resistance of the strain gage are linear and related by the relationship

$$(\Delta R/R)/(\Delta L/L)$$

which is defined as the Gage Factor (G.F.) or Strain Sensitivity Factor. Where  $\Delta R$  is the change in resistance,  $R$  is the initial resistance, and  $\Delta L/L$  is  $\epsilon$  or strain. This holds valid for small deformations. Again, the electrical resistance strain gage only measures deformations parallel to its orientation, or Normal Strains. Notice that strain,  $\epsilon = \Delta L/L$  or  $\epsilon = (\Delta R/R)/G.F.$

Gage factors for typical strain gages are approximately 2 and gages have a useful range of detecting strains from 1 – 10,000 microstrain.

The change in resistance that needs to be measured is extremely small and is difficult to measure accurately. To get a more accurate measurement, a bridge circuit is typically utilized in order to use the strain gage in a circuit where voltage or current changes can be accurately measured.

A basic Wheatstone bridge circuit contains four resistances, a constant voltage input, and a gage where output voltage can be measured.

Example:

For a given input voltage, currents ABC and ADC  
Depend on the resistances.

$$V_{in} = V_{abc} = V_{adc}$$

$$\text{So } i_{abc}(R_1 + R_2) = i_{adc}(R_4 + R_3)$$

Voltage drops from A => B and A => D are

$$V_{AB} = i_{ABC}R_1 = (V_{in}/(R_4+R_3))R_1$$

$$V_{AD} = i_{ADC}R_4 = (V_{in}/(R_4 + R_3))R_4$$

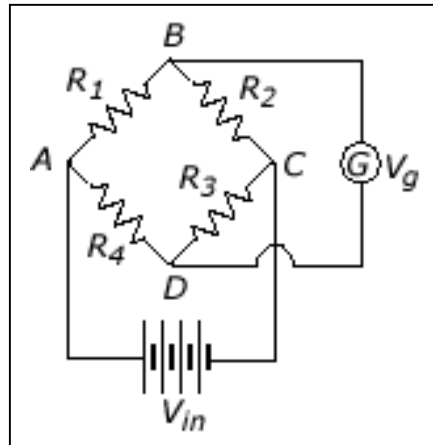

The voltage measured at the output can be obtained from

$$V_{out} = V_{AB} - V_{AD} = (V_{in}/(R_4+R_3))R_1 - (V_{in}/(R_4 + R_3))R_4$$

$$= V_{in}(((R_1R_3)/(R_1 + R_2)) - ((R_2R_3)/(R_4 + R_3)))$$

Suppose all resistances can change during measurement, the difference in output voltage will now become

$$V_{out} + \Delta V_{out} = V_{in} (R_1+\Delta R_2)(R_3+\Delta R_3)-(R_2+\Delta R_2)(R_4+\Delta R_4)/$$

$$(R_1+\Delta R_1+R_2 + \Delta R_2)(R_4+\Delta R_4+R_3+\Delta R_3)$$

A balanced bridge circuit such as is normally used to analyze strain with strain gages will use equal resistances where  $R_1 = R_2 = R_3 = R_4$ . Therefore the equation for change in voltage can be simplified to

$$V_{out} = V_{in}(\Delta R_1 - \Delta R_2 + \Delta R_3 - \Delta R_4) / 4R$$

Using the manufactured specified Gage Factor, strain can be directly measured accurately using the Wheatstone bridge circuit. Recall  $G.F. = (\Delta R/R) / (\Delta L/L)$

Application Examples:

The bridge circuit typically measures static resistance. By using a balanced bridge and attaching strain gages at key points of the member in question, certain errors inherent to

the types of measurements being taken can be compensated for such as changes in Temperature and other loading effects.

Consider the cantilever beam and loading shown.

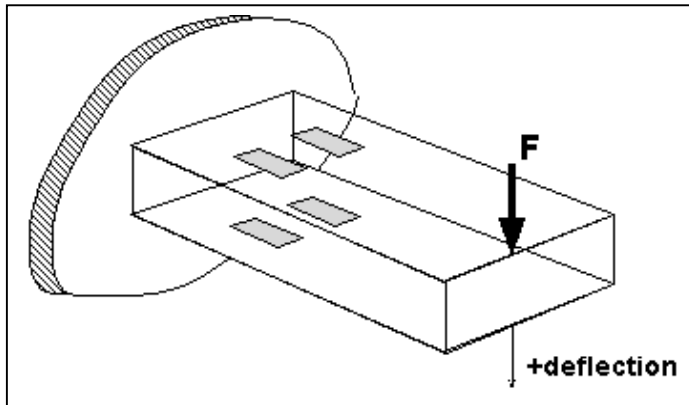

Assume this cantilever beam has a single gage located at the base on top to measure the strain in the beam. The single gage is put into Leg 1 of the bridge circuit and the circuit is balanced, this is known as a quarter bridge circuit. When loaded at the end of the beam, then strain gage causes the bridge to become unbalanced giving a reading that can be used to determine strain. Obviously the strain gage measures any deformation in the member it is attached to. From the cantilever beam example, engineering data is found utilizing general equilibrium equations relating the bending moment, stress and strain. In the case of bending stress, the only strain of interest is caused by the bending moment, any residual strains due to a small amount of axial deformation present or changes due to temperature differences will induce error into the data.

Using a dummy gage to compensate for temperature difference:

By taking a block of material the same basic geometry and type as the cantilever beam and attaching a strain gage to it, errors due to temperature fluctuations can be virtually eliminated. Recall the equation

$$V_{out} = V_{in}(\Delta R_1 - \Delta R_2 + \Delta R_3 - \Delta R_4) / 4R.$$

Using the strain gage mounted on the block (referred to as a dummy gage) and wiring it into leg 2 of the bridge circuit, any error due to temperature changes can now be eliminated, the bridge is now temperature compensated. Consider a temperature change over a set period of time; the dummy gage reading will change a certain amount depending on the thermal expansion characteristics of the material. By having a dummy gage made of the same material and a strain reading in leg 2 of the circuit, the equation becomes

$$V_{out} = V_{in}(\Delta R_1 - \Delta R_2)/4R.$$

The reading from leg 2 will clearly eliminate error due to temperature. This quarter bridge is therefore compensated.

Looking at a more complicated example, suppose on this cantilever beam there are 4 strain gages mounted to the member, two located on the top and two located on the bottom of beam as shown in the sketch. With the loading shown, the top gages will experience tension and the bottom gages will experience compression. Looking at the bridge circuit, substitute the top gages into Legs 1 and 4 of the circuit, and the bottom gages into legs 2 and 3, the change in resistance for all 4 gages will be equal in bending, but the difference in the top gages is positive, while the difference in the bottom gages is negative. Due to the current flow and readings in the gages, the bridge output will be 4 times larger than a single gage giving better resolution in the measurement. More important, it is obvious the strain gages in this particular configuration measure strain due to bending, but any strain resulting in temperature changes or residual axial loading effects will cause all four strain gages to change the same amount in the same direction. This will work to the advantage of canceling out these unwanted loading effects. Look again at the bridge circuit equation

$$V_{\text{out}} = V_{\text{in}}(\Delta R_1 - \Delta R_2 + \Delta R_3 - \Delta R_4) / 4R$$

Assume there is only an axial load on the beam, the change in resistance of the strain gages will be equal,  $\Delta R_1 = \Delta R_2 = \Delta R_3 = \Delta R_4$ . The resistance values will all cancel out in the equation, which results in the axial loading component being canceled out. This full bridge circuit compensates for temperature differences as well as axial loading components and yields better instrument resolution.

### **Strain Rosettes**

In order to measure the full state of strain on the surface of a part, we need to recognize that the 2D state of strain at a point the surface is defined by three independent quantities,  $\epsilon_x$ ,  $\epsilon_y$  and  $\phi_{xy}$ . This implies that is possible to find these 3 quantities if three independent measurements of strain at a point can be made. This is where a strain rosette comes into use. A rosette has three strain gages oriented in different directions with all of them located as close to the actual measuring point as possible. As long as the three strains and the gage directions are known, solving for the principle strains and their directions is possible.

Shown are a few examples of Strain rosette configurations.

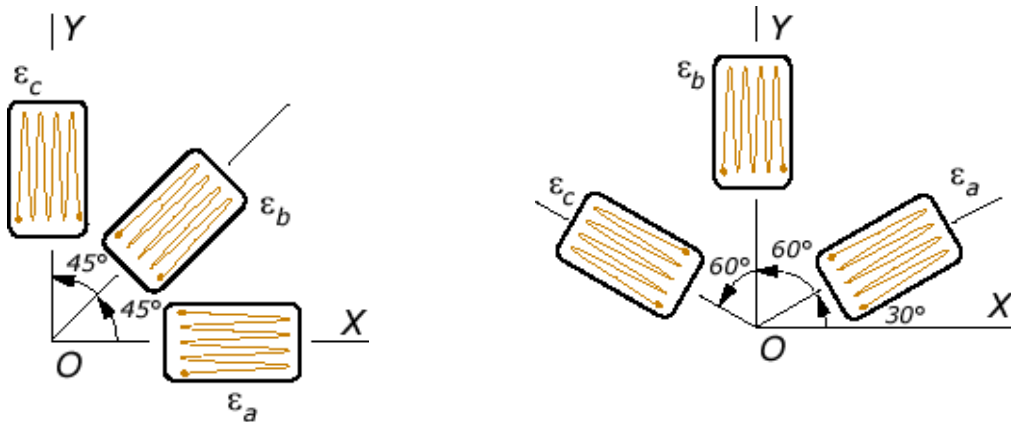

By using a simple two dimensional strain transformation equation

$$\epsilon_{x'} = (\epsilon_x + \epsilon_y)/2 + ((\epsilon_x - \epsilon_y)/2)\cos 2\theta + (\gamma_{xy} \sin 2\theta)/2$$

( where  $\epsilon_{x'}$  is the strain in any arbitrary direction  $x'$  )

three independent strain quantities can be found. These values make it easy to find normal as well as principle stresses at the point in question. Recognize that the surface where the strains are measured is generally free of significant normal surface stresses ( $\sigma_z = 0$ ) which reduces most surface analysis to a plane stress problem therefore simplifying the use of Hooke's law for multiaxial loading.

## **Tensile Test Overview**

Tensile testing is one of the more basic tests to determine stress – strain relationships. A simple uniaxial test consists of slowly pulling a sample of material in tension until it breaks. Test specimens for tensile testing are generally either circular or rectangular with larger ends to facilitate gripping the sample.

The typical testing procedure is to deform or “stretch” the material at a constant speed. The required load that must be applied to achieve this displacement will vary as the test proceeds. During testing, the stress in the sample can be calculated at any time by dividing the load over the cross-sectional area  $\sigma = P/A$

The displacement in the sample can be measured at any section where the cross-sectional area is constant and the strain calculated by taking this change in length and dividing it by the original or initial length  $\epsilon = \Delta L/L_0$

The stress and strain measurements and calculations discussed so far assume a fixed cross sectional area and a change in length that is measured within the constant cross sectional test area of the sample. These stress and strain values are known as engineering stress and engineering strain. The actual stress and strain in the materials for this type of test are higher than the engineering stress and strain; this is obvious when considering that as the tension and elongation increase, the volume of the section of material being tested decreases.

Since it is difficult to measure the actual cross section area during testing to obtain the actual stress values, the testing performed and evaluated in the following experiments will be based on the initial unrestrained geometry of the test sample and calculations will be performed to find the engineering stress and strain rather than the actual stress and strain.

Engineering material properties that can be found from simple tensile testing include the elastic modulus (modulus of elasticity or Young’s modulus), Poisson’s ratio, ultimate tensile strength (tensile strength), yield strength, fracture strength, resilience, toughness, % reduction in area, and % elongations. These values are typically calculated in tension experimentation and compared to published values.

Most of these engineering values are found by graphing the stress and strain values from testing. The modulus of elasticity can be calculated by finding the slope of the stress strain curve where it remains linear and constant. For the materials being tested in this lab, there will be an easily recognizable linear portion of the curve to calculate the elasticity value.

Where the stress strain curve starts to become non linear, this is known as the proportional limit. The proportional limit is also the point where yielding occurs in the material. At this point, the material no longer exhibits elastic behavior and permanent

deformation occurs. This onset of inelastic behavior is defined as the yield stress or yield strength. Some materials such as the mild steel used in this lab will have a well-defined yield point that can be easily identified on the stress strain curve. Other materials will not have a discernable yield point and other methods must be employed to estimate the yield stress. One common method is the offset method, where a straight line is drawn parallel to the elastic slope and offset an arbitrary amount, most commonly for engineering metals, 0.2%.

The highest stress or load the material is capable of will be the highest measurable stress on the graph. This is termed the ultimate strength or tensile strength. The point at which the material actually fractures is termed the fracture stress. For ductile materials, the Ultimate stress is greater than the fracture stress, but for brittle materials, the ultimate stress is equal the fracture stress.

Ductility is the materials ability to stretch or accommodate inelastic deformation without breaking. Another phenomenon that can be observed of a ductile material undergoing tensile testing is necking. The deformation is initially uniform along the length but tends to concentrate in one region as the testing progresses. This can be observed during testing, the cross sectional area of the highest stress region will visibly reduce.

Two final engineering values that will be determined from the stress strain curve are a measure of energy capacity The amount of energy the material can absorb while still in the elastic region of the curve is know as the modulus of resilience. The total amount of energy absorbed to the point of fracture is known as the modulus of toughness. These values can be calculated by estimating the respective areas under the stress strain curve. These values are measure of energy capacity, when finding the values under the curve, note that energy is work done per unit volume; therefore the units should be kept in terms of energy, or in-lb per cubic inch.

## EXPERIMENT A (TENSION EXPERIMENT)

A uniaxial tension test will be carried out on one of the labs universal testing machines. The testing machine will apply the load and an extensometer will record the corresponding strain during experimentation. The unit will record the load –deformation data during the experiment so this data can be plotted once the procedure is complete.

Obtain two sample coupons and record the geometry of each specimen.

Have the instructor give a brief explanation of the equipment, extensometer, and setup procedures before continuing on with the Tensile Test instructions.

### Tensile Test Instruction (T/O 60,000 lb machine)

#### *Pre-lab notes:*

Testing will consist of both a mild steel sample (low carbon, 1018 1020 etc) and an aluminum sample most likely machined from 6061-T6 stock. In order to set the appropriate scales on the data acquisition unit, the maximum load needs to be estimated. Due to variance in the ultimate strength values of various steels and aluminums tested, use the following values to assure the entire load range is recorded during testing.

$$\sigma_{ult} \text{ aluminum} = 64,000 \text{ psi} \qquad \sigma_{ult} \text{ steel} = 80,000 \text{ psi.}$$

*On the top portion of the graphs that will be generated, three sets of data are displayed; maximum load during testing, maximum strain, and maximum displacement. The maximum strain value can be ignored (the extensometer was physically removed during testing making this value redundant). The maximum displacement value can be used to calculate final strain at failure. The  $\Delta L$  value is the same value as the difference between the platen distances measured at the beginning and end of the test. Check and verify these values and include them in the lab write-up.*

- Turn on panel switch on the wall and laser printer switch at back of printer
- Secure the specimen between the jaws of the T/O
- Preload the specimen to approximately 300 lbs
- Lower the preload back to 50 lbs
- On the control panel, push “5” menu and remove all test results
- Install extensometer (Note: Extensometer gage length is 2.0 in.).
- Zero the scales (push buttons under the “zero” on panel)

- Change scales for the sample being tested. Scales are changed by going pressing Menu => User Interface => Graphics => Ranges => and selecting the appropriate axes. When changing the axis value, set secondary range same as first range if prompted. For both the Steel and Aluminum samples, set the Y-axis to record within the maximum calculated load, and the X-axis for a strain value of 0.02 in. For the Aluminum, set the Y-axis to record within the maximum calculated load and the X-axis for a strain value of 0.02 in.
- Push the “Clear” button, display should indicate READY in lower right hand corner
- Using a scale, measure the distance between the two platens before starting test and enter this value on the data sheet.
- Push the “Step” button to start data acquisition
- Set the speed to about halfway to 0.025 in/min
- Once the plot reaches the end of the strain scale visible on the graph, turn the speed control off and remove the extensometer. Resume the test and set the speed to approximately 0.025 in/min and continue testing until the specimen fails. Turn speed back to zero once failure has occurred.
- At this point, push the “Step” button again to stop recording. Push the “Print” button to get a copy of the graphical data.

Again measure the distance between the two platens. The strain at failure can be calculated allowing the entire data set to be graphed.

### **Data Reduction:**

Determine and tabulate the following:

- % Elongation
- Reduction in Area (%)
- Modulus of Elasticity
- Yield Strength
- Ultimate Tensile Strength
- Modulus of Resilience
- Modulus of Toughness

Generate two stress-strain graphs for each sample, one showing the linear portion of the curve to just after the yield point and the other showing the entire response curve from initial loading to failure. On these graphs, clearly label important regions, areas and/or points on the plot that correspond to the data that were calculated. The graphs that were generated in the lab are raw data and should be attached with the data sheets at the back of the report.

## **Torsion Test Overview**

Testing of round circular samples is another method of determining a basic engineering relationship in structural materials. Unlike tensile testing, torsional tests are not complicated by the phenomenon of necking and reduction in areas.

A simple torsion test is relatively easy to perform, the angle of twist is increased at a constant rate and the corresponding torque is measured at predetermined increments. These values can be graphed to find a number of engineering values. As in a tensile test, there will be an elastic or linear portion of the curve where a proportional relationship can be used to determine engineering values. In a Torque vs. Angle of twist relationship, the value that will be determined is the modulus of rigidity, also known as the shear modulus. By using the polar moment of inertia and a specific length of shaft, the torque and angle of twist can be used to determine the shear modulus using the following relationship

$$\phi = TL/JG$$

where T is the applied torque

L is the length of the sample being tested

J is the polar moment of inertia

G is the shear modulus

$\phi$  is the angle of rotation within the tested length.

Note the relationship between the modulus of elasticity, E, and G the modulus of rigidity within the linear elastic range of the material is described by Hooke's law, which relates E, G, and Poisson's ration,  $\nu$ . The knowledge of any two can be used to find the third using the relationship

$$E = 2G / (1 + \nu)$$

It is easy to recognize that the torsional test measures shear stress vs. shear strain to find the shear modulus where as in a tensile test, axial stress and axial strain are used to determine Young's modulus.

Engineering values or material properties that can be found from torsional testing include the shear modulus, proportional limit shear stress, and the proportional modulus of rupture. The shear stress is at a maximum at the outside surface of the material and can be calculated using the relationship  $\tau = Tc/j$ , the highest shear stress that the material can withstand and still return to its original geometry is at the limit of the proportional portion of the graph and is know as the proportional limit shear stress. The torsional modulus of rupture is the stress calculated at rupture.

Finding the modulus of Rigidity is a simple matter of graphing the Shear stress vs. Shear strain and finding the slope within the linear elastic range.

The shear strain is given as

$$\gamma_{xy} = \phi c/L$$

c is the radius of the solid circular sample

L is the length over which the angle of twist is measured

$\phi$  is the angle of twist.

The corresponding shear stress is  $\tau = Tc/j$ .

## EXPERIMENT B (TORSION EXPERIMENT)

Obtain two torsion coupons and measure the geometry of each specimen

Have the instructor explain the equipment setup and procedures of the testing experiment. Notice the torsionmeter divisions are given in 0.001-inch increments. Look carefully at the distance between the centerline of the torsionmeter clamping assembly and where the plunger at the back of the dial indicator contacts the assembly bar. This distance is precisely one inch. Using the geometric relationship for the arc length of a circle  $s = r\theta$ , a correlation between linear and angular displacement can be found.



Generate a graph while the experiment is being performed, or carefully watch the data to determine when the plot becomes non-linear. When the graph passes the proportional limit or becomes non-linear, the straining head hand-wheel can be advanced at much larger increments, or applied continuously while carefully watching the torque reading.

### **Data Reduction:**

- Plot curves of torque vs. angle of twist for both the aluminum and steel specimens on a single graph
- Determine the modulus of rigidity for each specimen
- Calculate the proportional limit shear stress for each specimen
- Calculate the torsional modulus of rupture for each specimen

## **Beam Experiment Overview**

A beam is typically defined as a slender bar capable of supporting transverse loading perpendicular to the bar. An applied transverse load to a beam results in internal forces of shear and bending moments.

In earlier experiments testing various materials in the lab, axial and torsional loads carried similar internal forces that were constant within the test portion of the sample. With beams, this may not be the case. Depending on how the beam is loaded, shear forces and bending moments may vary continuously along the length of the beam. It is important in analyzing a beam and its corresponding loading to construct accurate shear and bending moment diagrams to visually determine what forces are acting on the member.

There will be two types of stresses on the transverse section of the beam, normal stress caused by bending moments as well as shear stresses due to shear forces applied to the beam. The distribution of these shear forces and bending forces must be visually shown in order to accurately compute stresses and deflections of the beam.

Beams can be classified depending on their respective supporting conditions. Two supporting conditions used are the pinned support, which limits or restricts transverse motion of the beam while allowing rotation about the pin, and the roller support, this is a pinned type connection that allows movement parallel to the axis of the beam while suppressing any transverse motion. A cantilever beam is attached or built in to a rigid support at one end and free at the opposite end. An overhanging beam is supported by a pin on one end, and a roller on the other end. The beam extending beyond the supports on either or both ends where a load may be present. A simply supported beam has a pinned support at one end and a roller support at the opposite end like the overhanging beam but does not extend beyond the supports where loading can be applied.

The three types of beams described are all considered statically determinate beams because the reactions at the supporting points can be easily found using equilibrium equations.

The simply supported beam to be analyzed in one of the lab experiments is equipped with five strain gages attached to the beam, four of these strain gages are attached axially between the supporting points and loading points (two on top and two on the bottom), and the fifth is located at the center of the beam attached laterally on the top of the beam. The location of the strain gages in relation to the loading points and support points is irrelevant due to the symmetry of this particular setup and loading conditions required. As a shear and bending moment diagram is constructed, this will become clearly obvious.

## EXPERIMENT C (CANTILEVER BEAM EXPERIMENT)

Cantilever beam with two attached strain gages, and one dummy gage.

For the test procedure, three strain gage configurations will be required.

- 1)  $\frac{1}{4}$  bridge using only the upper strain gage
- 2)  $\frac{1}{2}$  bridge using the upper and lower gages
- 3)  $\frac{1}{2}$  bridge using the upper and the dummy gage

(Make sure adequate measurements are taken from the beam)

### Data Reduction:

- Compare the experimental and theoretical results
- Plot the experimental and theoretical data on one graph for comparison

A good understanding “Strain Gage Theory” in the lab manual will help in the lab write-up. A discussion of the advantages, disadvantages or any other relative information regarding the three strain gage configurations should be included in the write-up. Also included in the write-up will be the following question:

Given the following data, determine the principal stresses, maximum shear stress, and direction of principle stresses with respect to the  $0^0$  axis. Use  $E = 30 \times 10^6$  psi and a Poisson’s ratio of 0.30. See instructor for specific data values.

$$\varepsilon_{x'} = (\varepsilon_x + \varepsilon_y)/2 + ((\varepsilon_x - \varepsilon_y)/2)\cos 2\theta + (\phi_{xy} \sin 2\theta)/2$$

( where  $\varepsilon_{x'}$  is the strain in any arbitrary direction  $x'$  )

$$\varepsilon \text{ at } 0^0 = \underline{\hspace{2cm}}$$

$$\varepsilon \text{ at } 60^0 = \underline{\hspace{2cm}}$$

$$\varepsilon \text{ at } 120^0 = \underline{\hspace{2cm}}$$

Draw a Mohr’s circle of stress and show all stress values that were calculated on this plot. Draw two stress elements and show the stress  $\sigma_x$ ,  $\sigma_y$ , and  $\tau_{xy}$  on one element,  $\sigma_{\min}$  and  $\sigma_{\max}$  on the second element, and show the angle  $\theta_p$  for the principal stresses between these two elements.

## **EXPERIMENT D (SIMPLY SUPPORTED BEAM EXPERIMENT)**

Before beginning experiment, calculate the safe load,  $P$ , and the corresponding deflection. This should be part of the data sheet and included in the report. Use an allowable stress of 18,000 psi for these calculations. Also, make sure to have a 0-2 inch travel indicator and magnetic base set up under the beam in order to determine the experimental midspan deflection data.

Include with the report a sketch of the beam along with shear and bending moment diagrams of the beam.

### **Data Reduction:**

- Determine the flexural modulus of elasticity for each load using the load and deflection data
- Calculate the experimental and theoretical flexural stresses between the load points (for the experimental values, use the experimentally calculated modulus of elasticity from the first step above).
- Calculate the experimental values of Poisson's ratio for each test load and compare to published values
- Calculate the theoretical deflection for each load.
- Calculate and Plot a graph of load vs. deflection for both experimental and theoretical midspan deflections of the beam. These plots should be on the same graph for comparison

## ***Combined Loading Experiment***

So far in the testing carried out in this lab, the primary focus has been finding uniaxial strain and stresses as well as shearing strains and stress in both tensile testing as well as torsional testing. When a member is subjected to a combined loading, analysis of stresses becomes more difficult as it is now a matter of multiaxial stress. In the case of multiaxial loading, Poisson's ratio allows the extension of Hooke's law for uniaxial loading to biaxial and triaxial loading. These formulas are shown in most mechanics of materials textbooks and can be utilized to find stresses in any desired direction with experimentally determined strain values.

The combined loading experiment utilizes a hollow aluminum tube fixed at one end in the form of a cantilever beam. At the opposite end or the free end of the tube, a moment arm is attached to apply a torque to the tube and a weight hanger at the center of the free end simultaneously applies a bending moment to the beam.

At the top of the beam close to the fixed end, there is a strain rosette attached in order to measure strains in three directions. Recall from mechanics of materials and strength of materials studies, the state of plane strain at a point is determined by three strain components,  $\epsilon_x$ ,  $\epsilon_y$  and  $\phi_{xy}$ . In order to determine a state of strain, three separate strain readings are necessary. Since there is no piece of equipment to measure the shear strain,  $\phi_{xy}$ , it must be determined indirectly, which can easily be accomplished by utilizing strain transformation equations. The strain rosette used in the experiment is a 0, 45, 90 degree stacked type rosette.

## EXPERIMENT E (COMBINED LOADING ANALYSIS)

The strain rosette located on the top of the cantilever beam has 6 wires attached to it. The three strain gages oriented at 45 degrees from each other have two wires attached to each strain gage. By experimenting with different loads on the weight hangers, it can be determined which colored sets of wires go to which strain gage if the connections are not visible. Make sure to determine and sketch the rosette and corresponding colored leads before attempting to start the experiment. Also, make sure to record the dimensions of the beam and loading arm. This particular Aluminum beam has an O.D. of 2.00" and an I.D. of 1.902". Use a modulus of elasticity value of  $E = 10 \times 10^6$  psi and a Poisson's ratio of 0.33.

Set up a spreadsheet to calculate stresses by using the following strain transformation equation and assuming a thin element at the strain rosette location. There needs to be a clear sketch included with the report showing the element and the corresponding x-y coordinates used for calculation purposes.

$$\epsilon_{x'} = (\epsilon_x + \epsilon_y)/2 + ((\epsilon_x - \epsilon_y)/2)\cos 2\theta + (\gamma_{xy} \sin 2\theta)/2$$

( where  $\epsilon_{x'}$  is the strain in any arbitrary direction  $x'$  )

Clearly show the x – y coordinates used in relation to the beam and rosette.

It may be helpful to find a relationship that can be used in the spreadsheet to solve for the required unknowns. The spreadsheet should clearly show the following for each loading performed:

- Experimentally obtained values of normal strain
- Transformed strain values (x, y and shearing strain)
- Stresses in the x and y direction and shear stress
- Principle stresses and maximum shear stresses
- Principle angle

Include a separate table comparing theoretical and experimental values for all stresses and the corresponding angle. Generate two Mohr's circles on the same plot (experimental and theoretical) for the 2 lb. loading.

Note: Show all formulas used in the sample calculation section.

## **Column Buckling Test Overview**

A column is a stressed member, which carries a compressive axial load. Columns generally fail due to three different conditions.

Short Columns fail due to crushing. Even if eccentric loading is present, a short column will undergo little lateral deflection causing the failing method to be solely compression.

Long columns fail by buckling. If the compressive forces are steadily increased, a critical load will be reached, the straight shape of the column becomes unstable and will deflect laterally and eventually collapse. The stresses that cause long columns to buckle are typically much less than the yield stress or proportional limit of the material.

Intermediate Columns will fail by a combination of both buckling and crushing. This particular failure mechanism is difficult to predict, so empirical formulas derived from experimentation are used to approximate strength.

There is a critical load that will cause all columns to buckle, this load simply defined is the maximum load a column can carry and still remain straight. At this critical load, the column is still axially straight but is unstable, any sideways or lateral force applied to the column at this point would cause deflection and failure. Therefore, the lateral stiffness of the column at the critical load is zero.

Leonard Euler (1707 – 1783) derived a formula for calculating the critical load of a column based on the differential equation of the elastic curve  $P_y = M = -EI \frac{d^2y}{dx^2}$ . This particular equation relates the critical load to the geometry and mechanical properties of the material/

Euler's equation for critical load

$$P_{cr} = \pi^2 EI / L_e^2.$$

Where  $P_{cr}$  is the critical load,  $I$  is the moment of inertia of the cross section of the column,  $E$  is Young's Modulus or the Modulus of Elasticity and  $L_e$  the effective length of the column.

The effective length of the column is dependant on the method of restraining the ends of the member. The case where both column ends are set up in a pinned condition is considered the fundamental case. The critical load is very sensitive to the end restraint of the column. Depending on end restraint conditions, the effective length that is used for calculations is given by the following:

Pinned – Pinned end conditions	$L_e = L$
Pinned – Fixed end conditions	$L_e = 0.7L$
Fixed – Fixed end conditions	$L_e = 0.5L$

Looking at Euler's equation, it should be obvious that the buckling load is not dependant on the strength of the material, but on the modulus of elasticity and the columns physical geometry. This indicates that two identically geometric samples of steel will buckle under the same critical load regardless of material strength. Therefore, the critical load given by Euler's equation is only valid if the stress at buckling does not exceed the yield stress or proportional limit of the material.

The stress just before buckling can be calculated by substituting  $I = Ar_g^2$  into Euler's equation, where  $r_g$  is the least radius of gyration of the cross section  $r_g = (I/A)^{1/2}$ , the equation becomes  $\sigma_{cr} = P_{cr}/A = (\pi^2 E) / (L_e/r_g)^2$  where  $\sigma_{cr}$  is known as the critical stress and  $L_e/r_g$  is the slenderness ration of the column. Again, as long as the proportional limit of the material is not exceeded by the Critical Stress, Euler's equation for critical load is valid.

For long columns,  $\sigma_{cr} < \sigma_{pl}$ . The dividing line between long and intermediate columns is the slenderness ratio. Larger slenderness rations apply to Euler's equation, but for smaller slenderness rations, the column will fail in a combination of both buckling and crushing. Looking back at the concepts to clarify this, Long columns fail in buckling where  $\sigma_{cr} < \sigma_{pl}$ , but intermediate columns fail in both crushing and buckling where  $\sigma_{cr} > \sigma_{pl}$ . Here, other methods of predicting the buckling load must be employed.

One such method is an empirical method found through testing and defined by AISC ( American Institute of Steel Construction ) as the Parabolic Formula, used where the column slenderness ration is considered small. AISC defines the dividing line between intermediate and long columns to be the critical slenderness ration, which employs the yield stress of the material. The critical slenderness ratio given for Steel is  $C_c = (2\pi^2 E / \sigma_y^2)^{1/2}$ . For slenderness rations below this value, the following parabolic formula may be used.  $\sigma_{cr} = P_{cr}/A = \sigma_y ( 1 - ((L_e/r_g)^2) / 2C_c^2)$  and for larger slenderness ration where  $L_e/r_g > C_c$ , Euler's equation may be employed.

## EXPERIMENT F (THE COLUMN EXPERIMENT)

Setup and procedures will be demonstrated at the beginning of the experiment. Crosshead speed during experimentation should be 0.05 in. / min.

The following table is a guideline that can be used to setup the group data sheet. This is not to be used as the data sheet for the experiment. The information given is what will be needed to write up this report.

Plot a smooth curve for the experimental as well as theoretical values of  $P_{cr}$  vs. effective slenderness ratio on one graph for comparison.

Note: for every fixed end condition specified, the initial length of the column will be reduced by 1/2 inch due to the configuration of the buckling fixture.

Instron 1100 Column Buckling Experiment				1/16 dia.welding rod (steel)		
		$\sigma_y$ (assumed) = 130000		psi		
$C_c =$		A =		in. <sup>2</sup>		
$I =$		in. <sup>4</sup>	$r_g =$	in.		
( Note: 1/2 in. of column is used in fixtures to model a fixed end )						
Length (in.)	End cond	$L_e/r_g$	$P_{cr}$ ex (lb <sub>f</sub> )	$P_{cr}$ th (lb <sub>f</sub> )	% Diff.	Eq. Used
1.25	ff					
2.50	ff		In one table, compare the data shown above for all columns.			
1.25	pf					
2.50	pf					
1.00	pp		In a separate table, compare the critical load for the 1.25 in. columns (pp, pf, and ff) and the 2.5 in. columns (pp,pf, and ff). This will simply show and obvious increase in load capacity by fixing one or more column ends.			
1.25	pp					
1.50	pp					
2.00	pp					
2.25	pp					
2.50	pp					
Parabolic Eq. ( $0 < L_e/r_g < C_c$ ) $\sigma_{cr} = \sigma_y(1-(L_e/r_g)^2/2(C_c^2))$						
Euler's Eq. ( $C_c < L_e/r_g < 200$ ) $\sigma_{cr} = (\pi^2 E)/(L_e/r_g)^2$						

# Appendix A

## Quick Reference – Selected Material Properties

This table contains commonly used reference data for engineering materials.								
Material	Modulus of		Modulus of		Poisson's Ratio	Unit Weight, w		
	Elasticity, E		Rigidity, G			lb/	lb/	kN/
	Mpsi	GPa	Mpsi	GPa		in <sup>3</sup>	ft <sup>3</sup>	m <sup>3</sup>
Aluminum alloys	10.3	71.0	3.8	26.2	0.334	0.098	169	26.6
Beryllium Copper	18.0	124.0	7.0	48.3	0.285	0.297	513	80.6
Brass	15.4	106.0	5.82	40.1	0.324	0.309	534	83.8
Carbon Steel	30.0	207.0	11.5	79.3	0.292	0.282	487	76.5
Cast Iron, grey	14.5	100.0	6.0	41.4	0.211	0.260	450	70.6
Copper	17.2	119.0	6.49	44.7	0.326	0.322	556	87.3
Douglas Fir	1.6	11.0	0.6	4.1	0.33	0.016	28	4.3
Glass	6.7	46.2	2.7	18.6	0.245	0.094	162	25.4
Inconel	31.0	214.0	11.0	75.8	0.290	0.307	530	83.3
Lead	5.3	36.5	1.9	13.1	0.425	0.411	710	111.5
Magnesium	6.5	44.8	2.4	16.5	0.350	0.065	112	17.6
Molybdenum	48.0	331.0	17.0	117.0	0.307	0.368	636	100.0
Monel metal	26.0	179.0	9.5	65.5	0.320	0.319	551	86.6
Nickel silver	18.5	127.0	7.0	48.3	0.322	0.316	546	85.8
Nickel steel	30.0	207.0	11.5	79.3	0.291	0.280	484	76.0
Phosphor bronze	16.1	111.0	6.0	41.4	0.349	0.295	510	80.1
Stainless steel	27.6	190.0	10.6	73.1	0.305	0.280	484	76.0

*Shigley, Mechanical Engineering Design, 1980, McGraw Hill*

# Appendix B

## Glossary

### *Mechanical Properties and Tests A - Z*

Engineering materials are commonly defined and specified by their properties. And of all the properties a material may possess, mechanical properties often are the most important because virtually all fabrication processes and most service conditions involve some type of mechanical loading. Thus, in selecting materials you must know the mechanical properties of a material and what they stand for. As this glossary shows, there are literally hundreds of different mechanical properties and terms. And behind each property there generally is a test that defines the property and tells how to measure it. Thus, a large part of our "picture" of a material is based on the sum of its mechanical properties and tests for measuring these properties. Here is a summary of the properties, tests and terms you should know in order to make an intelligent choice of materials.

*( Michael G. Busch., Associate Editor Materials Engineering )*

**Adherence.** The extent to which a coating bonds to a substrate.

**Adherence index.** Measure of the adherence of porcelain enamel and ceramic coatings to sheet metal. (ASTM C-313).

**Alpha Rockwell hardness.** Index of the resistance of a plastic to surface penetration by a specified indenter under specified load applied with a Rockwell hardness tester. Higher values indicate higher indentation hardness. (ASTM D-786).

**Annealing point.** Temperature at which internal stress in glass is substantially relieved in 15 min. (ASTM C-336).

**ASTM hardness number.** Depth (in thousandths of an inch) of penetration of an indenter into a rubber specimen under loads and conditions specified in ASTM D-314. While suitable for most common grades of rubber, ASTM hardness number is not applicable to extremely hard or soft rubbers.

**Bearing area.** Area through which a bearing load is transmitted. Diameter of bearing hole multiplied by thickness of specimen is area used to compute bearing stress.

**Bearing load.** Compressive load transmitted to a structural member through area of contact (bearing area).

**Bearing stiffness.** Slope of the tangent at any point on the stress-strain diagram plotted from data obtained in test for bearing strength. (ASTM D-953, plastics and ASTM E-238, metals). Gives an indication of the behavior of materials subjected to edge-wise loads such as applied through mechanical fasteners. Strain used to determine bearing stiffness is defined as % deformation of bearing hole through which the load is applied.

**Bearing strength.** Measure of maximum usable bearing stress that can be developed in a material. Equal to the stress that corresponds to the point on the bearing stress-strain diagram where the slope of the curve equals the stress divided by a strain of 4%. A standard procedure for determining bearing strength is given in ASTM D-953 (plastics) and ASTM E-238 (metals). While it is known that materials with higher compressive and tensile strengths have higher bearing strengths, there is no widely accepted method for estimating bearing strength from compression or tensile properties.

**Bearing stress.** Bearing load applied to a material divided by original bearing area. In the bearing strength test (ASTM D-593 for plastics, ASTM E-238 for metals) a rectangular specimen is loaded in tension or compression by a pin or rod passing through a bearing hole. Bearing stress and bearing strain are recorded as bearing load is increased and are plotted to form a stress strain diagram. Maximum bearing stress is equal to load at rupture divided by original bearing area.

**Bend test.** Method for measuring ductility of certain materials. There are no standardized terms for reporting bend test results for broad classes of materials; rather, terms associated with bend tests apply to specific forms or types of materials. For example, materials specifications sometimes require that a specimen be bent to a specified inside diameter (ASTM A-360, steel products). Results of bend test of welds are given as fiber

elongation (ASTM E-16). And results of tests of fiberboard are reported by a description of the failure or photographs. (ASTM D-1037).

**Bending strength.** Alternate term for flexural strength. It is most commonly used to describe flexure properties of cast iron and wood products. **Bond strength.** Stress (tensile load divided by area of bond) required to rupture a bond formed by an adhesive between two metal blocks. (ASTM D-952).

**Breaking load.** Load which causes fracture in a tension, compression, flexure or torsion test. In tension tests of textiles and yarns, breaking load also is called breaking strength. In tensile tests of thin sheet materials or materials in form of small diameter wire it is difficult to distinguish between breaking load and the maximum load developed so the latter is considered the breaking load.

**Breaking strength.** Tensile load or force required to rupture textiles (e.g., fibers, yarn) or leather. It is analogous to breaking load in a tension test. Ordinarily, breaking strength is reported as lb or lb/in. of width for sheet specimens.

**Brinell hardness number (BHN).** Measure of the indentation hardness of metals, calculated from the diameter of the permanent impression made by a ball indenter of a specified size pressed into the material by a specified force. BHN increases with increasing indentation hardness. A standard test for determining BHN is given in ASTM E-10.

Conversion tables that relate BHN to diamond pyramid hardness, Rockwell hardness and Rockwell superficial hardness are published in ASTM E-140. BHN test is particularly useful where deep penetration is required to avoid surface effects or where a large impression is required to avoid errors due to inhomogeneity of material. It is not used for thin sections or very hard materials.

**Brittle fracture.** Failure or rupture of a material with little or no plastic flow or deformation of a metal's crystal lattice. Usually this type of failure is associated with impact loads. However, many materials at low temperatures also show brittle fracture failures under static loads. Two common methods for determining resistance to brittle fracture are the Izod and Charpy impact tests. (ASTM E-23).

**Brittleness temperature.** Temperature at which plastics and elastomers exhibit brittle failure under impact conditions specified in ASTM D 746. Brittleness temperature often is used as part of specifications for plastics or elastomers, but is not considered an accurate measure of materials lowest use temperature. A test for determining brittleness temperature of plastic film is given in ASTM D-1790.

**Bulk modulus of elasticity.** Ratio of stress to change in volume of a material subjected to axial loading. Related to modulus of elasticity (E) and Poisson's ration ( $\nu$ ) by the following equation:  $K = E\nu / 3(1 - 2\nu)$ .

**Bursting strength.** Measure of ability of materials in various forms to withstand hydrostatic pressure. For round rigid plastic tubing it usually is reported as internal fluid

pressure required to produce rupture (ASTM D-1180). For coated fabrics it is reported as force required to rupture a diaphragm divided by its area. (ASTM D-751).

**Charpy impact test.** Method for determining behavior of materials under conditions favorable to brittle fracture. Used where results of a tension impact test would not be significant. It is the most popular impact test. Test is performed by striking a notched specimen supported as simple beam with a falling weight. Results are reported as energy absorbed in fracture and a description of the fracture. ASTM E-23 describes test for metals, ASTM A 327 for cast iron, ASTM D-256 for plastics and ASTM D-758 for plastics at subnormal and elevated temperatures.

**Clash-Berg test.** Method for determining stiffness of plastics as a function of temperature by a torsion test (ASTM D-1043). Test consists of direct measurements of apparent modulus of rigidity over wide temperature range.

**Cleavage strength.** Tensile load (lb/in. of width) required to cause separation of a 1-in. long metal-to-metal adhesive bond under the conditions set in ASTM D-1062.

**Climbing drum peel test.** Method for determining peel resistance of adhesive bond between a relatively flexible and rigid material. (ASTM D1781).

**Coefficient of elasticity.** Alternate term for modulus of elasticity.

**Cohesive strength.** Theoretical stress that causes fracture in tension test if material exhibits no plastic deformation.

**Cold crushing strength.** Load required to produce fracture in refractory bricks and shapes divided by average cross section area of specimen. (ASTM C-133).

**Cold flow.** Permanent deformation of plastics remaining after load applied at temperature below distortion temperature is removed. It is an alternate term for creep in plastics (ASTM D-674) and rubber (ASTM D-530).

**Complex modulus.** Measure of dynamic mechanical properties of material taking into account energy dissipated as heat during deformation and recovery. It is equal to the sum of static modulus of a material and its loss modulus. In the case of shear loading it is called dynamic modulus. See also damping capacity.

**Compressibility.** Extent to which material is compressed in test for compressibility and recovery of gasket materials (ASTM F-36). It is usually reported with recovery.

**Compressibility and recovery test.** Method for measuring behavior of gasket materials under short time compressive loading at room temperature. ASTM F-36 outlines a standard procedure. Test is not designed to indicate long term (creep) behavior and should not be confused with the plastometer test.

**Compression-deflection test.** Nondestructive method for determining relationship between compressive load and deflection under load for vulcanized rubber. (ASTM D-575). Compression fatigue. Ability of rubber to sustain repeated fluctuating compressive loads. (ASTM D-623).

**Damping capacity.** Measure of the ability of a material to absorb vibration by converting mechanical energy in to heat. It is equal to the area of the elastic hysteresis loop divided by the deformation energy of a vibrating material. It can be calculated by measuring the rate of decay of vibrations induced in a material. For details see "Mechanical Properties of Polymers," L. E. Nielsen, Reinhold Publishing Corp.; "Nondestructive Testing," W. y. McGonagle, McGraw-Hill Book Co. and "Mechanical Testing of Materials," A. J. Fenner, Philosophical Library Inc.

**Deflection temperature.** Temperature at which a plastic specimen deforms a specified amount under a specified load. It is not a direct guide to the high temperature limit of a plastic for a specified application, but rather a means for comparing the relative heat resistance of plastics. (ASTM D-648).

**Deformation energy.** Energy required to deform a material a specified amount. It is the area under the stress-strain diagram up to a specified strain.

**Deformation under load.** Measure of the ability of rigid plastics to withstand permanent deformation and the ability of nonrigid plastics to return to original shape after deformation. Standard test methods for determining both types of deformation under load are given in ASTM D-621. For rigid plastics deformation (which can be flow or flow and shrinkage) is reported as % change in height of specimen after 24 hr under a specified load. For nonrigid plastics results are reported as % change in height after 3 hr under load and recovery in the 1 1/2 hr period following removal of the load. Recovery is % increase in height calculated on basis of original height.

**Delamination strength.** Measure of the node-to-node bond strength of honeycomb core materials. It is equal to the tensile load applied to a honeycomb panel at fracture divided by its width times thickness. (ASTM C-363).

**De Mattia flexing machine test.** Method for measuring the cracking resistance (ASTM D-430) and crack growth resistance of rubber (ASTM D-813).

**Diamond pyramid hardness number (DPHN).** Measure of the indentation hardness of a material. It is the amount of plastic deformation caused by a 136 deg pyramidal diamond indenter under a specified load. (ASTM E-92). Also known as Vickers hardness.

**Dissipation factor.** Ratio of the loss modulus to static modulus of a material under dynamic loading. It is proportional to damping capacity. An alternate term is loss tangent.

**Drop ball impact test.** Method for determining the energy absorption characteristics of a material subjected to shock loading. Metal ball of known weight is dropped on specimen from regularly increasing heights and height of drop, producing failure is reported. Test is used for hard metals, ceramics and plastics.

**Drop weight test.** Method for determining the nil-ductility transition temperature of steel. Results are reported as temperature above which specimens no longer show brittle fracture after specified shock loadings. (ASTM E-208).

**Dry strength.** Strength of an adhesive joint determined immediately after drying or after a period of conditioning in a specified atmosphere. (ASTM D-1144).

**Ductile-to-brittle transition temperature.** Indication of temperature range in which metals undergo transition from ductile to brittle behavior. It is an indication of the minimum temperature at which metals have sufficient ductility for forming. For some refractory metals ductile-to-brittle transition temperatures are well above room temperature.

**Ductility.** Extent to which a material can sustain plastic deformation without rupture. Elongation and reduction of area are common indices of ductility.

**Du Pont flexing machine test.** Method for determining the cracking resistance of rubber (ASTM D-430). Rubber specimens are mounted to a fabric base and subjected to tensile and compressive flexing until failure occurs. Results are reported as a comparison of the severity of cracking in various samples, and number of cycles required to produce specified severity of cracking in the material.

**Durometer hardness.** Measure of the indentation hardness of plastics and rubber. It is the extent to which a spring loaded steel indenter protrudes beyond a pressure foot into the material. Standard procedures are given in ASTM D-1706 (plastics) and ASTM D-2240 (plastics and rubber).

**Dynamic creep.** Creep that occurs under fluctuating load or temperature.

**Dynamic ductility test.** Method for determining ductility of zinc strip or sheet. A series of cups are formed by a plunger and depth of deepest nonruptured cup is reported. (ASTM B-69).

**Dynamic modulus.** Complex modulus of material under dynamic shear loading. It is equal to the sum of static shear modulus and loss modulus. Dynamic modulus takes into account energy dissipated as heat when material is deformed.

**Dynamic modulus, effective.** Indication of the vibration absorption characteristics of elastomers. It is determined in the Yerzley mechanical oscillograph test (ASTM D-945). It is not an actual physical modulus, but an extension of dynamic modulus beyond the straight line portion of the load-deformation curve.

**Eccentricity of loading.** Distance between the actual line of action of compressive or tensile loads and the line of action that would produce a uniform stress over the cross section of the specimen.

**Edge distance ratio.** Distance from the edge of a bearing strength test specimen to the center of the bearing hole, divided by the diameter of the hole. Edge distance ratio is generally reported with results of a bearing strength test.

**Edge tearing strength.** Measure of the resistance of paper to tearing when folded over a V-notch beam and loaded in a tensile testing machine (ASTM D-827). Results are reported in lb or kg. See also tear resistance.

**Elastic hysteresis.** Difference between strain energy required to generate a given stress in a material and elastic energy at that stress. It is the energy dissipated as heat in a material in one cycle of dynamic testing. Elastic hysteresis divided by elastic deformation energy is equal to damping capacity.

**Elastic limit.** Greatest stress that can be applied to a material without causing permanent deformation. For metals and other materials that have a significant straight line portion in their stress-strain diagram, elastic limit is approximately equal to proportional limit. For materials that do not exhibit a significant proportional limit, elastic limit is an arbitrary approximation (apparent elastic limit).

**Elastic limit, apparent.** Arbitrary approximation of the elastic limit of materials that do not have a significant straight line portion on a stress-strain diagram. It is equal to the stress at which the rate of strain is 50% greater than at zero stress. It is the stress at the point of tangency between the stress-strain curve and a line having a slope with respect to the stress axis 50% greater than the slope of the curve at the origin.

**Elasticity.** Ability of a material to return to its original shape when load causing deformation is removed.

**Elongation.** Measure of the ductility of a material determined in a tension test. It is the increase in gage length (measured after rupture) divided by original gage length. Higher elongation indicates higher ductility. Elongation cannot be used to predict behavior of materials subjected to sudden or repeated loading.

**Embrittlement.** Reduction in ductility due to physical or chemical changes.

**Endurance limit.** Alternate term for fatigue limit.

**Energy absorption.** Energy required to fracture a specimen in an impact test. It is a measure of toughness or impact strength. Nil ductility transition temperature is derived from a series of energy absorption measurements at various temperatures.

**Engineering stress.** Load applied to a specimen in a tension or compression test divided by a cross section area of the specimen. The change in cross section area that occurs with increases and decreases in applied load is disregarded in computing engineering stress. It is also called conventional stress.

**Erichsen test.** Cupping test in which a sheet metal blank restrained at its edges is deformed at its center by a cone-shaped, spherical-end plunger until fracture occurs. Height of the cup (in mm) at fracture is an indication of ductility. (ASTM A-344).

**Expansion test.** Control and acceptance test for determining ductility of nonferrous metal tubing. A tapered pin is forced into the end of tubing to produce a specified increase in tube diameter. The tube is then examined for failure. (ASTM B-153). An alternate term is pin test.

**Extensometer.** Instrument for measuring changes in linear dimensions. Also called a strain gage.

**Fatigue.** Permanent structural change that occurs in a material subjected to fluctuating stress and strain. However, in the case of glass, fatigue is determined by long-term static testing and is analogous to stress rupture in other materials. In general, fatigue failure can occur with stress levels below the elastic limit.

**Fatigue life.** Number of cycles of fluctuating stress and strain of a specified nature that a material will sustain before failure occurs. Fatigue life is a function of the magnitude of the fluctuating stress, geometry of the specimen and test conditions. An S-N diagram is a plot of the fatigue life at various levels of fluctuating stress.

**Fatigue limit.** Maximum fluctuating stress a material can endure for an infinite number of cycles. It is usually determined from an S-N diagram and is equal to the stress corresponding to the asymptote of the locus of points corresponding to the fatigue life of a number of fatigue test specimens. An alternate term is endurance limit.

**Fatigue notch factor.** Ratio of fatigue strength of a specimen with no stress concentration to fatigue strength of a specimen with a notch or other stress raisers. Fatigue notch factor is usually lower than the theoretical stress concentration factor because of stress relief due to plastic deformation. An alternate term is strength reduction ratio.

**Fatigue ratio.** Ratio of fatigue strength or fatigue limit to tensile strength. For many materials fatigue ratio may be used to estimate fatigue properties from data obtained in tension tests.

**Fatigue strength.** Magnitude of fluctuating stress required to cause failure in a fatigue test specimen after a specified number of cycles of loading. Usually determined directly from the S-N diagram.

**Fatigue strength reduction factor.** An alternate term for fatigue notch factor.

**Fatigue test.** A method for determining the behavior of materials under fluctuating loads. A specified mean load (which may be zero) and an alternating load are applied to a specimen and the number of cycles required to produce failure (fatigue life) is recorded. Generally, the test is repeated with identical specimens and various fluctuating loads. Loads may be applied axially, in torsion or in flexure. Depending on amplitude of the mean and cyclic load, net stress in the specimen may be in one direction through the loading cycle or may reverse direction.

Data from fatigue testing often are presented in an S-N diagram which is a plot of the number of cycles required to cause failure in a specimen against the amplitude of the cyclical stress developed. The cyclical stress represented may be stress amplitude, maximum stress or minimum stress. Each curve in the diagram represents a constant mean stress.

Most fatigue tests are conducted in flexure, rotating beam or vibratory type machines. Fatigue testing is generally discussed in "Manual on Fatigue Testing," ASTM STP 91-A and "Mechanical Testing of Materials," A. J. Fenner, Philosophical Library Inc. ASTM D-671 details a standard procedure for fatigue testing of plastics in flexure.

**Fiber stress.** Stress through a point in a part in which stress distribution is not uniform. For example, the stress in a beam under bending load varies from compression to tension across the beam. It is more meaningful in determining the properties of the beam material to consider the maximum stress generated in the outer fibers of the beam. Similarly, stress in a beam under twist loading is a maximum in the material furthest from the axis of twist.

**File hardness.** Simple determination of the comparative hardness of a metal. It is a statement as to whether a file does or does not bite into a material.

**Firestone flexometer test.** Method for determining compression fatigue characteristics of rubber. A pyramidal rubber specimen is subjected to an oscillating compressive load and the number of load cycles required to produce a specified deflection is reported. (ASTM D-623).

**Flare test.** Method for determining ductility of tubing material. It is similar to an expansion test and a pin test.

**Flattening test.** Measure of the ductility of metal pipe. A short section of pipe is crushed diametrically between parallel plates to a specified extent and examined for failure.

**Flex resistance.** Ability of foam rubber to sustain repeated compressive loads without damage to cell structure. (ASTM D-1055).

**Flexural modulus of elasticity.** Alternate term for modulus in bending.

**Flexural strength.** Maximum fiber stress developed in a specimen just before it cracks or breaks in a flexure test. Flexural yield strength is reported instead of flexural strength for materials that do not crack in the flexure test. An alternate term is modulus of rupture.

**Flexure test.** Method for measuring behavior of materials subjected to simple beam loading. It is also called a transverse beam test with some materials. Specimen is supported on two knife edges as a simple beam and load is applied at its midpoint. Maximum fiber stress and maximum strain are calculated for increments of load. Results are plotted in a stress-strain diagram, and maximum fiber stress at failure is flexural strength. Flexural yield strength is reported for materials that do not crack. Standard test procedures are given in ASTM D 790 (plastics), ASTM C-328 and ASTM C-369 (fired whiteware), ASTM D-797 (elastomers), ASTM A-438 (cast iron) and ASTM C-158 (glass).

**Flow stress.** Stress required to cause plastic deformation.

**Fluting diameter.** Smallest diameter about which sheet metal can be bent to form a smooth curve rather than a series of planes with a fluted appearance.

**Fracture stress.** True stress generated in a material at fracture.

**Fracture test.** Visual test wherein a specimen is fractured and examined for grain size, case depth, etc.

**Fracture toughness.** Ability of a material to resist crack propagation when subjected to shock load as in an impact test.

**Gehman torsional test.** Method for measuring low temperature stiffening of rubber by a calibrated torsion wire. (ASTM D-1053). Results often are reported as apparent modulus of rigidity, which is equal to three times Young's modulus.

**Goodrich flexometer test.** Method for determining compression fatigue characteristics of rubber having a durometer hardness less than 8.5. (ASTM D-623). Results may be reported as temperature rise during continued cyclic loading, permanent set in a specified time, duration of heat buildup, maximum temperature rise or time to failure.

**Hardness.** Measure of a material's resistance to localized plastic deformation. Most hardness tests involve indentation, but hardness may be reported as resistance to scratching (file test), or rebound of a projectile bounced off the material (scleroscope hardness). Some common measures of indentation hardness are Brinell hardness number, Rock well hardness number, ASTM hardness number, diamond pyramid hardness number, durometer hardness, Knoop hardness and Pfund hardness number. A table relating various type of hardness values of metals is given in ASTM E-140. Hardness often is a good indication of tensile and wear properties of a material.

**Heat distortion point.** Temperature at which a standard plastic test bar deflects 0.010 in. under a maximum fiber stress of 66 or 264 psi. (ASTM D-648). An alternate term is deflection temperature.

**Heat distortion temperature.** An alternate term for deflection temperature.

**Hooke's law.** Stress is directly proportional to strain. Hooke's law assumes perfectly elastic behavior. It does not take into account plastic or dynamic loss properties.

**Hoop stress.** Circumferential stress in a cylinder subjected to internal hydrostatic pressure. For thin wall cylinders it can be calculated by Barlow's formula:  $S = PD/2t$  where S is hoop stress in psi; P, applied pressure in psi; D, cylinder o.d. in in.; and t, wall thickness in in. Barlow's formula does not hold for thick-wall cylinders where stress varies across wall thickness.

**Hot hardness.** Measure of hardness at elevated temperature. Often it is determined by heating a specimen, removing it from the oven and testing it with standard hardness testers. However, this is not a true indication of hardness at temperature because the surface cools quickly after removal from the oven and surface properties are critical in hardness testing. Several methods and apparatus for hot hardness testing are described in "Property Measurements at High Temperatures," W. D. Kingrey, John Wiley & Sons, Inc.

**Impact energy.** Energy required to fracture a part subjected to shock loading as in an impact test. Alternate terms are impact value, impact strength, impact resistance and energy absorption.

**Impact resilience.** Measure of the resilience of rubber obtained by dropping a pendulum hammer against a specimen and measuring rebound. (ASTM D-1054). It is the ratio of 1 minus the cosine angle of rebound, to 1 minus the cosine of the original angle of the pendulum, and is expressed as a %. It is sometimes called % rebound. Impact resilience of metal is an indication of hardness obtained in a rebound test such as the test for scleroscope hardness.

**Impact strength.** Energy required to fracture a specimen subjected to shock loading, as in an impact test. Alternate terms are impact energy, impact value, impact resistance and energy absorption. It is an indication of the toughness of a material.

**Impact test.** A method for determining behavior of material subjected to shock loading in bending, tension or torsion. The quantity usually measured is the energy absorbed in breaking the specimen in a single blow, as in the Charpy impact test, Izod impact test and tension impact test. Impact tests also are performed by subjecting specimens to multiple blows of increasing intensity, as in the drop ball impact test and repeated blow impact test. Impact resilience and scleroscope hardness are determined in nondestructive impact tests.

**Indentation hardness.** Resistance of material to surface penetration by an indenter. See hardness.

**International rubber hardness degrees (IRHD).** Measure of indentation hardness of rubber. For substantially elastic isotropic rubbers IRHD is related to Young's modulus by the equation:  $F/M = 0.00017 R^{0.65} P^{1.35}$  where F is indenting force in kg; M, Young's modulus in kg/sq cm; R, radius of indenter in cm, and P, penetration in hundredths of mm. IRHD of a rubber is approximately equal to its durometer hardness. A standard test method for determining IRHD is given in ASTM D-1415.

**Izod impact test.** Method for determining behavior of materials subjected to shock loading. Specimen supported as a cantilever beam is struck by a weight at the end of a pendulum. Impact strength is determined from the amount of energy required to fracture specimen. ASTM E-23 describes a standard test procedure, specimens (including notch shapes) and apparatus for Izod impact testing of metals. See also ASTM A-327 (cast iron), ASTM D-256 (plastics) and ASTM D-758 (plastics at sub normal and elevated temperatures). See also Impact test.

**Kink test.** Method for determining ductility of metal wire. A short section of wire is looped and drawn in tension to produce a kink. Relative ductility is indicated by the occurrence or non-occurrence of failure and extent to which kink may be opened up without failure.

**Knoop hardness number.** Measure of indentation hardness of a material (especially an organic coating) measured with a pyramidal diamond indenter of prescribed dimensions. (ASTM D-1474).

**Knot strength.** Tenacity of a fiber in which an overhand knot is tied. Knot strength is a measure of a fiber's sensitivity to compressive and shear stresses.

**Load-deflection diagram.** Plot of load vs corresponding deflection.

**Loss factor.** Ratio of the real and imaginary components of complex modulus. Term is used in connection with dynamic tests to determine damping capacity of materials and combinations of materials. An alternate term is loss tangent.

**Loss modulus.** Imaginary component of complex modulus. It takes into account mechanical energy dissipated as heat during deformation of a material under dynamic loading.

**Loss tangent.** An alternate term for loss factor.

**Low temperature brittleness test.** A method for measuring the resistance of rubbers and rubber-like materials to brittle cracking at low temperatures. Specimens are exposed to a specified temperature for 4 hr and flexed. Results are reported as failure or non-failure at specified temperatures. (ASTM D-736).

**Low temperature compression set.** Measure of the ability of vulcanized rubber loaded at room temperature and subsequently subjected to prolonged exposure at low temperatures to recover from deformation at the low temperature. It is the % compressive deformation retained by a specimen subjected to the standard test set out in ASTM D-1229. The test simulates conditions encountered by seal and gasket materials used in aircraft and submarines.

**Low temperature stiffening.** Measure of the effect of temperature change on the stiffness of rubber and rubber like materials. It is usually reported as the temperature at which a material has a specified relative modulus. (ASTM D-1063). See also Gehman torsional test.

**Maximum fiber stress.** Maximum tensile or compressive stress in a homogeneous flexure or torsion test specimen. For a specimen loaded as a simple beam at its midpoint, maximum fiber stress occurs at mid-span and may be calculated by the formula (for rectangular specimens):  $S=3PL/2bd^2$  where S is maximum fiber stress; P, load; L, span; b, width of the beam and d, depth of the beam. For a circular cross section member loaded in torsion, maximum fiber stress may be calculated by the following formula:  $S=Tr/J$  where T is twisting moment; r, original outer radius and J, polar moment of inertia of original cross section.

**Mean stress.** Algebraic difference between maximum and minimum stress in one cycle of fluctuating loading as in a fatigue test. Tensile stress is considered positive and compressive stress negative.

**Mechanical hysteresis.** Alternate term for elastic hysteresis.

**Microhardness.** Hardness of microscopic areas. Microhardness values differentiate hardness of constituents in a material.

**Minimum bend radius.** Minimum radius to which a sheet or wire can be bent to specified angle without failure.

**Modulus.** Alternate term for modulus of elasticity, often used in connection with rubber.

**Modulus in bending.** Ratio of maximum fiber stress to maximum strain within elastic limit of stress-strain diagram obtained in flexure test. Alternate term is flexural modulus of elasticity.

**Modulus of elasticity.** Rate of change of strain as a function of stress. The slope of the straight line portion of a stress-strain diagram. Tangent modulus of elasticity is the slope of the stress-strain diagram at any point. Secant modulus of elasticity is stress divided by strain at any given value of stress or strain. It also is called stress strain ratio. Tangent and secant modulus of elasticity are equal up to the proportional limit of a material.

Depending on the type of loading represented by the stress-strain diagram, modulus of elasticity may be reported as compressive modulus of elasticity (or modulus of elasticity in compression), flexural modulus of elasticity (or modulus of elasticity in flexure), shear modulus of elasticity (or modulus of elasticity in shear), tensile modulus of elasticity (or modulus of elasticity in tension) or torsional modulus of elasticity (or modulus of elasticity in torsion). Modulus of elasticity may be determined by dynamic mechanical testing where it can be derived from complex modulus.

Modulus used alone generally refers to tensile modulus of elasticity. Shear modulus is almost always equal to torsional modulus and both are called modulus of rigidity. Moduli of elasticity in tension and compression are approximately equal and are known as Young's modulus. Modulus of rigidity is related to Young's modulus by the equation:  $E = 2G(1 + \nu)$  where E is Young's modulus (psi), G is modulus of rigidity (psi) and  $\nu$  is Poisson's ratio. Modulus of elasticity also is called elastic modulus and coefficient of elasticity.

**Modulus of rigidity.** Rate of change of strain as a function of stress in a specimen subjected to shear or torsion loading. It is the modulus of elasticity determined in a torsion test. Alternate terms are modulus of elasticity in torsion and modulus of elasticity in shear.

Apparent modulus of rigidity is a measure of the stiffness of plastics measured in a torsion test (ASTM D-1043). It is "apparent" because the specimen may be deflected past its proportional limit and the value calculated may not represent the true modulus of elasticity within the elastic limit of the material.

**Modulus of rupture.** Ultimate strength determined in a flexure or torsion test. In a flexure test, modulus of rupture in bending is the maximum fiber stress at failure. In a torsion test, modulus of rupture in torsion is the maximum shear stress in the extreme fiber of a circular member at failure. Alternate terms are flexural strength and torsional strength.

**Modulus of strain hardening.** Alternate term for rate of strain hardening.

**Monotron hardness.** Measure of indentation hardness. It is the load (kg) required to press a specified ball indenter to a specified depth. Indenters consist of 1 mm diamond (M-2), 1/16 in. tungsten carbide (M-3) and 2.5 mm tungsten carbide (M-4). Standard

depth of indentation is 0.045 mm, but for hard materials depth of indentation may be limited is multiplied by 3.

**Necking.** Localized reduction of cross section area of a specimen under tensile load. It is disregarded in calculating engineering stress but is taken into account in determining true stress.

**Nil ductility transition temperature.** Temperature above which a specimen no longer shows brittle fracture in a drop weight test. (ASTM E-208).

**Nominal stress.** Stress calculated on the basis of the net cross section of a specimen without taking into account the effect of geometric discontinuities such as holes, grooves, fillets, etc.

**Notch brittleness.** Phenomena by which brittle fracture occurs more readily in notched specimens than in notch free specimens.

**Notch ductility.** Reduction in area of a notched specimen at fracture in a tension test.

**Notch sensitivity.** Measure of reduction in load-carrying ability caused by stress concentration in a specimen.

**Offset yield strength.** Arbitrary approximation of elastic limit. It is the stress that corresponds to the point of intersection of a stress-strain diagram and a line parallel to the straight line portion of the diagram. Offset refers to the distance between the origin of the stress-strain diagram and the point of intersection of the parallel line and the 0 stress axis. Offset is expressed in terms of strain (often 0.2%).

**Olsen cup test.** Method for measuring metal ductility by determining cup height. A sheet metal blank, restrained on all edges, is deformed by pressing a specified steel ball at its center. Height (or depth) of the cup when rupture occurs is reported in thousandths of an inch.

**Operating stress.** Stress imposed on a part in service.

**Overstressing.** Application of high fluctuating loads at the beginning of a fatigue test and lower loads toward the end. It is a means for speeding up a fatigue test

**Peel resistance.** Torque required to separate an adhesive and adherent in the climbing drum peel test. (ASTM D-1781). It is a measure of bond strength.

**Peel strength.** Measure of the strength of an adhesive bond. It is the average load per unit width of bond line required to part bonded materials where the angle of separation is 180 deg and separation rate is 6 in./min. (ASTM D-903).

**Penetration.** Depth to which the striker of a rebound pendulum penetrates a rubber specimen under conditions set in ASTM D-1054. It is an index of the dynamic stiffness or complex modulus of rubber specimens.

**Permanent set.** Extent to which a material is permanently deformed by a specified load. Usually expressed as % and calculated by dividing the difference in dimensions in the direction of loading before loading and after the load is removed by the original dimension and multiplying by 100.

**Pfund hardness number (PHN).** Measure of the indentation hardness of coatings. Hemispherical quartz or sapphire indenter is used. (ASTM D1474).

**Photoelasticity.** Method for observing stress distribution in a part through the use of a transparent model.

**Pin test.** Alternate term for expansion test.

**Plastic deformation.** Deformation that remains after the load causing it is removed. It is the permanent part of the deformation beyond the elastic limit of a material. It also is called plastic strain and plastic flow.

**Plasticity.** Tendency of a material to remain deformed after reduction of the deforming stress to a value equal to or less than its yield strength.

**Plasticity number.** Index of the compressibility of rubber at elevated temperatures. Equal to 100 times the height of a standard specimen after 3 to 10 min compression by a 5 kg load. (ASTM D-926).

**Plastometer test.** Method for determining ability of rubber to be compressed at an elevated temperature and to recover at room temperature. Results are reported as plasticity number and recovery. Test differs from compressibility and recovery test in that the latter measures behavior of material subjected to short-time loading at room temperature.

**Poisson's ratio.** Ratio of lateral strain to axial strain in axial loaded specimen. It is the constant that relates modulus of rigidity to Young's modulus in the equation:  $E = 2G(r + 1)$  where E is Young's modulus; G, modulus of rigidity and r, Poisson's ratio. The formula is valid only within the elastic limit of a material. A method for determining Poisson's ratio is given in ASTM E-1321.

**Proof stress.** Stress that will cause a specified permanent deformation.

**Proportional limit.** Highest stress at which stress is directly proportional to strain. It is the highest stress at which the curve in a stress-strain diagram is a straight line. Proportional limit is equal to elastic limit for many metals.

**Pusey and Jones indentation.** Measure of indentation hardness of rubber. It is the depth of penetration of a ball indenter under a load applied by a plastometer. (ASTM D-531).

**Rate of strain hardening.** Rate of change of true stress as a function of true strain in a material undergoing plastic deformation. An alternate term is modulus of strain hardening.

**Recovery.** Index of a material's ability to recover from deformation in the compressibility and recovery test (ASTM F-36), the deformation under load test (ASTM D-621) and the plastometer test (ASTM D-926). In the compressibility and recovery test it is usually reported with compressibility and given as %. It is calculated by dividing the difference between recovered thickness and thickness under load by the difference between original thickness and thickness under load. In the deformation under load test it indicates the extent to which a nonrigid plastic recovers from prolonged compressive deformation at elevated temperature. It is given as % and is calculated by dividing the difference between height recovered 1 1/2 hr after load is removed and height after three hr of loading by the change in height under load. In the plastometer test it indicates the extent to which an elastomer recovers from compressive loading at elevated temperature. It is equal to plasticity number minus recovered height. See also Rockwell recovery.

**Recovery test.** Method for measuring compressibility and recovery of gasket and seal materials. (ASTM F 36).

**Reduction of area.** Measure of the ductility of metals obtained in a tension test. It is the difference between original cross section area of a specimen and the area of its smallest cross section after testing. It is usually expressed as % decrease in original cross section. The smallest cross section can be measured at or after fracture. For metals it usually is measured after fracture and for plastics and elastomers it is measured at fracture.

**Relative modulus.** Ratio of the modulus of a rubber at a given temperature to its modulus at 73 F. It is determined in the Gehman torsional test.

**Relaxation.** Rate of reduction of stress in a material due to creep. An alternate term is stress relaxation.

**Repeated bent test.** Method for determining ductility of relatively ductile metals such as silicon steel sheet and strip. Specimens about 1 in. wide and 6 in. long are held in jaws and bent 90 deg. Then they are bent back and forth through 180 deg. Results are reported as number of bends (including the original 90 deg bend) required to cause failure. (ASTM A-344).

**Repeated blow impact test.** Method for judging impact properties of cast iron. Hammer is dropped on specimen from increasing heights until fracture occurs. Results are reported as height of the last drop prior to fracture (repeated blow impact value). (ASTM A-327).

**Residual elongation.** Measure of ductility of plastics. It is the elongation of a plastic specimen measured 1 min after rupture in a tension test.

**Resilience.** Measure of recoverable elastic energy in a deformed material. It is the amount of energy released when a load is removed from a specimen. It is equal to deformation energy minus electric hysteresis.

**Rockwell hardness number (RHN).** Index of indentation hardness measured by a steel ball or diamond cone indenter. RHN is given in various scales (B, C, R, etc.) depending on indenter and scales used. ASTM E-18 details a standard method for determining RHN for metals and gives a table of scale symbols. ASTM D-785 gives standard method for

measuring RHN of plastics; ASTM B-294 covers cemented carbides and ASTM A-370, steel products.

**Rockwell penetration.** Measure of indentation hardness of rubber. It is the resistance to penetration by a specified indenter under specified load applied with a Rockwell hardness tester. (ASTM D-530). It usually is reported with Rockwell recovery.

**Rockwell recovery.** Extent to which hard rubber recovers from indentation. It is obtained in same test as Rockwell penetration (ASTM D-530) and is reported with it.

**Rockwell superficial hardness.** Measure of surface hardness of thin strip or finished parts on which large test marks cannot be tolerated or shapes that would collapse under normal Rockwell hardness test loads. (ASTM E-18).

**Ross flexing machine test.** Method for measuring crack growth resistance of rubber by repeatedly bending pierced specimen and measuring growth of crack that develops. (ASTM D-1052).

**Rupture resistance.** Indication of ability of rubber to withstand tensile loading. It is the load required to rupture a rubber specimen under conditions set out in ASTM D-530.

**Rupture strength.** Nominal stress developed in a material at rupture. It is not necessarily equal to ultimate strength. And, since necking is not taken into account in determining rupture strength, it seldom indicates true stress at rupture.

**S-N diagram.** Plot of stress (S) against the number of cycles (N) required to cause failure of similar specimens in a fatigue test. Data for each curve on an S-N diagram are obtained by determining fatigue life of a number of specimens subjected to various amounts of fluctuating stress. The stress axis can represent stress amplitude, maximum stress or minimum stress. A log scale is almost always used for the N scale and sometimes for the S scale.

**St. Joe flexometer test.** Method for measuring compression fatigue characteristics of rubber. Results are reported as time and flexing load required to fail specimen. (ASTM D-623).

**Scleroscope hardness.** Measure of hardness or impact resilience of metals. A diamond-tipped hammer falls freely against specimen from a fixed height and rebound height is measured. Scleroscope hardness is read on an empirical scale where 100 represents average rebound from a quenched high carbon steel specimen. ASTM A-427 contains a table that relates scleroscope hardness to diamond pyramid hardness.

**Scratch hardness.** Method for determining comparative hardness of materials by measuring width of a scratch made by a scribe drawn across the surface under specified pressure. Often performed on coatings.

**Secant modulus of elasticity.** Ratio of stress to strain at any point on curve in stress-strain diagram. It is the slope of a line from the origin to any point on stress-strain curve.

**Shear modulus of elasticity.** Tangent or secant modulus of elasticity of a material subjected to shear loading. Alternate terms are modulus of rigidity and modulus of elasticity in shear. Also, shear modulus of elasticity usually is equal to torsional modulus of elasticity. A method for determining shear modulus of elasticity of structural materials by means of a twisting test is given in ASTM E-143. A method for determining shear modulus of structural adhesives is given in ASTM E-229.

**Shear strength.** Maximum shear stress that can be sustained by a material before rupture. It is the ultimate strength of a material subjected to shear loading. It can be determined in a torsion test where it is equal to torsional strength. The shear strength of a plastic is the maximum load required to shear a specimen in such a manner that the resulting pieces are completely clear of each other. It is reported in psi based on the area of the sheared edge. (ASTM D-732). The shear strength of a structural adhesive is the maximum shear stress in the adhesive prior to failure under torsional loading. (ASTM E-229). Methods for determining shear strength of timber are given in ASTM D-143 and ASTM D-198.

**Softening point.** Temperature at which a uniform fiber of glass elongates under its own weight at a specified rate. (ASTM C-338). The Vicat softening point of plastics is the temperature at which a flat ended needle of 1 sq mm circular or square cross section penetrates a thermoplastic specimen to a depth of 1 mm under load and conditions specified in ASTM D-1525.

**Splitting resistance.** Measure of the ability of felt to withstand tearing. It is the load required to rupture a slit felt specimen by gripping lips of the cut in jaws and pulling them apart. (ASTM D-461). An alternate term is tear resistance.

**Springback.** Degree to which a material returns to its original shape after deformation. In plastics and elastomers it is also called recovery.

**Stiffness.** Measure of resistance of plastics to bending. It includes both plastic and elastic behavior, so it is an apparent value of elastic modulus rather than a true value. (ASTM D-747).

**Strain.** Change per unit length in a linear dimension of a part or specimen, usually expressed in %. Strain as used with most mechanical tests is based on original length of the specimen. True or natural strain is based on instantaneous length and is equal to  $\ln l/l_0$  where  $l$  is instantaneous length and  $l_0$  is original length of the specimen. Shear strain is the change in angle between two lines originally at right angles.

**Strain energy.** Measure of energy absorption characteristics of a material under load up to fracture. It is equal to the area under the stress strain diagram, and is a measure of the toughness of a material.

**Strain hardening exponent.** Measure of increase in hardness and strength caused by plastic deformation. It is related to true stress and true strain by the equation:  $\sigma = \sigma_0 \epsilon^n$  where  $\sigma$  is true stress,  $\sigma_0$  is true stress at unit strain,  $\epsilon$  is true strain and  $n$  is strain hardening exponent.

**Strain point.** Temperature at which internal stress in glass is substantially relieved in about 1 hr. (ASTM C 336).

**Strain rate.** Time rate of elongation.

**Strain relaxation.** Alternate term for creep of rubber.

**Strength reduction ratio.** Alternate term for fatigue notch factor.

**Stress.** Load on a specimen divided by the area through which it acts. As used with most mechanical tests, stress is based on original cross section area without taking into account changes in area due to applied load. This sometimes is called conventional or engineering stress. True stress is equal to the load divided by the instantaneous cross section area through which it acts.

**Stress amplitude.** One-half the range of fluctuating stress developed in a specimen in a fatigue test. Stress amplitude often is used to construct an S-N diagram.

**Stress concentration factor.** Ratio of the greatest stress in the area of a notch or other stress raiser to the corresponding nominal stress. It is a theoretical indication of the effect of stress concentrators on mechanical behavior.

Stress concentration factor usually is higher than the empirical fatigue notch factor or strength reduction ratio because it does not take into account stress relief due to local plastic deformation.

**Stress corrosion cracking.** Failure of a material due to combined effects of corrosion and stress. Generally, stress corrosion cracking refers to the phenomenon by which stress increases corrosion rate.

**Stress ratio.** Ratio of minimum stress to maximum stress in one cycle of loading in a fatigue test. Tensile stresses are considered positive and compressive stresses negative.

**Stress relaxation.** Decrease in stress in a material subjected to prolonged constant strain at a constant temperature. Stress relaxation behavior is determined in a creep test. Data often is presented in the form of a stress vs time plot. Stress relaxation rate is slope of the curve at any point.

**Stress rupture strength.** Alternate term for creep strength.

**Stress-strain diagram.** Graph of stress as a function of strain. It can be constructed from data obtained in any mechanical test where a load is applied to a material and continuous measurements of stress and strain are made simultaneously. It is constructed for compression, tension and torsion tests.

**Stress-strain ratio.** Stress divided by strain at any load or deflection. Below the elastic limit of a material it is equal to tangent modulus of elasticity. An alternate term is secant modulus of elasticity. Stripping strength. Alternate term for peel strength.

**Tangent modulus of elasticity.** Instantaneous rate of change of stress as a function of strain. It is the slope at any point on a stress-strain diagram.

**Tear length.** Measure of the drawability of sheet metal. Two small parallel slots are cut in the edge of the sheet to form a tab which is gripped and torn from the sheet. The variation in length of tabs torn in different directions is an indication of crystal orientation in the sheet. (Tabs torn in the direction of orientation are longer.) The degree of orientation is an indication of difficulty to be expected in drawing the sheet to uniform shapes.

**Tear resistance.** Measure of the ability of sheet or film materials to resist tearing. For paper it is the force required to tear a single ply of paper after the tear has been started. (ASTM D-689). Three standard methods are available for determining tear resistance of plastic films: ASTM D-1004 details a method for determining tear resistance at low rates of loading. A test in ASTM D-1922 measures the force required to propagate a pre-cut slit across the sheet specimen. ASTM D-1038 gives a method for determining tear propagation resistance that is recommended for specification acceptance testing only. Tear resistance of rubber is the force required to tear a 1 in. thick specimen under the conditions outlined in ASTM D-624. Tear resistance of textiles is the force required to propagate a single-rip tongue-type tear (starting from a cut) by means of a falling pendulum apparatus. (ASTM D-1424).

**Tearing strength.** Tensile force required to rupture a pre-slit woven fabric specimen under the conditions out-lined in ASTM D-2261 and ASTM D-2262. Edge tearing strength of paper is the force required to tear a specimen folded over a V-notch and loaded in a tensile test machine. (ASTM D-827).

**Temper test.** Method for measuring the ability of strip or sheet metal to recover its original shape after bending. Temper of strip and sheet metals for electronic devices is measured by clamping a rectangular specimen in a rotatable clamp, bending it and recording the angle of spring-back. (ASTM F-155). To determine temper of zinc strip, a rectangular specimen is clamped in a rotating mandrel, pressed against the mandrel and released. Spring back is reported in a scale based on the apparatus used. (ASTM B-69).

**Tenacity.** Force required to break a yarn or filament expressed in grams per denier. It is equal to breaking strength divided by denier.

**Tensile impact energy.** Energy required to break a plastic specimen in tension by a single swing of a calibrated pendulum. (ASTM D-1822). It is a measure of impact strength obtained in a tension impact test.

**Tensile modulus of elasticity.** Tangent or secant modulus of elasticity of a material subjected to tensile loading. Alternate terms are Young's modulus and modulus of elasticity in tension. It can be measured in a tension test or in a dynamic test where it is related to resonant frequency of a cylindrical rod by the equation:  $E = 412 \frac{12 p f^2}{k^2 j^4}$  where E is modulus of elasticity; l, length of the rod; p, density; f, resonant frequency; k, radius of gyration of the rod about an axis normal to the rod axis and plane of motion ( $d/4$  for cylindrical rods) and j, a constant dependent on the mode of vibration. Tensile

modulus of elasticity is approximately equal to compressive modulus of elasticity within the proportional limit. An alternate term is Young's modulus.

**Tensile strength.** Ultimate strength of a material subjected to tensile loading. It is the maximum stress developed in a material in a tension test.

**Tension impact test.** Method for determining energy required to fracture a specimen under shock tensile loading. (ASTM D-1822).

**Tension set.** Extent to which vulcanized rubber is permanently deformed after being stretched a specified amount for a short time. It is expressed as % of original length or distance between gage marks (ASTM D-412).

**Tension test.** Method for determining behavior of materials under axial stretch loading. Data from test are used to determine elastic limit, elongation, modulus of elasticity, proportional limit, reduction in area, tensile strength, yield point, yield strength and other tensile properties. Tension tests at elevated temperatures provide creep data.

Procedures for tension tests of metals are given in ASTM E-8, ASTM E-150 (creep tension tests) and ASTM E-151 (elevated temperatures). Methods for tension tests of plastics are outlined in ASTM D 638, ASTM D-2289 (high strain rates), ASTM D-882 and ASTM D 1923 (thin sheets) and ASTM D 795 (high and low temperatures). ASTM D-2343 outlines a method for tension testing of glass fibers; ASTM D-897, adhesives; ASTM D-987, paper products; ASTM D 412, vulcanized rubber.

**Thermal stress.** Internal stress in part caused by uneven heating.

**Time for rupture.** Time required to rupture specimen under constant stress and temperature in a creep test.

**Torque twist diagram.** Graph of torque vs torsional deformation plotted from data obtained in a torsion test.

**Torsion resistance.** Measure of the resistance to cracking of porcelain enamel coatings on an iron or steel substrate when the base metal is twisted. (ASTM D-409).

**Torsion test.** Method for determining behavior of materials subjected to twisting loads. Data from torsion test is used to construct a stress strain diagram and to determine elastic limit, torsional modulus of elasticity, modulus of rupture in torsion and torsional strength. Shear properties are often determined in a torsion test. (ASTM E-143).

**Torsional deformation.** Angular displacement of specimen caused by a specified torque in torsion test. It is equal to the angular twist (radians) divided by gage length (in.).

**Torsional modulus of elasticity.** Modulus of elasticity of material subjected to twist loading. It is approximately equal to shear modulus and also is called modulus of rigidity.

**Torsional strain.** Strain corresponding to a specified torque in the torsion test. It is equal to torsional deformation multiplied by the radius of the specimen.

**Torsional strength.** Measure of the ability of a material to withstand a twisting load. It is the ultimate strength of a material subjected to torsional loading, and is the maximum torsional stress that a material sustains before rupture. Alternate terms are modulus of rupture and shear strength.

**Torsional stress.** Shear stress developed in a material subjected to a specified torque in torsion test. It is calculated by the equation:  $s = Tr/J$  where T is torque, r is the distance from the axis of twist to the outer most fiber of the specimen and J is the polar moment of inertia

**Torsional Yield strength.** Yield strength of material under twist loading.

**Toughness.** Extent to which a material absorbs energy without fracture. It is usually expressed as energy absorbed in an impact test. The area under a stress-strain diagram also is a measure of toughness of a material. (ASTM D-256, plastics and ASTM E-23, metals).

**Transition temperature.** Alternate term for ductile-to-brittle transition temperature.

**Transverse bend test.** Alternate term for flexure test, often used in connection with cast iron.

**True strain.** Instantaneous % change in length of specimen in mechanical test. It is equal to the natural logarithm of the ratio of length at any instant to original length.

**True stress.** Applied load divided by actual area of the cross section through which load operates. It takes into account the change in cross section that occurs with changing load.

**Twisting test.** Method for measuring shear properties of structural materials. (ASTM E-143).

**Ultimate elongation.** Alternate term for elongation of material at rupture under tensile loading.

**Ultimate strength.** Highest engineering stress developed in material before rupture. Normally, changes in area due to changing load and necking are disregarded in determining ultimate strength

**Vicat softening point.** Temperature at which a flat-ended needle of 1 sq mm cross section penetrates a thermoplastic material to a depth of 1 mm under conditions and loads set out in ASTM D-1525.

**Vickers hardness.** Alternate term for diamond pyramid hardness.

**Wet strength.** Breaking strength of paper saturated with water. Also, the strength of an adhesive bond after immersion in water.

**Wrapping diameter.** Measure of wire ductility. It is the minimum diameter to which wire can be wound without causing failure.

**Yerzley mechanical oscillograph test.** Method for determining the dynamic mechanical properties of rubber. (ASTM D-945). Results of test are reported as deformation energy, effective dynamic modulus and Yerzley resilience.

**Yerzley resilience.** Measure of resilience of rubber subjected to dynamic loading.

**Yield point.** Stress at which strain increases without accompanying increase in stress. Only a few materials (notably steel) have a yield point and generally only under tension loading.

**Yield point elongation.** Strain at yield point of a material. It is an indication of ductility.

**Yield strength.** Indication of maximum stress that can be developed in a material without causing plastic deformation. It is the stress at which a material exhibits a specified permanent deformation and is a practical approximation of elastic limit.

Offset yield strength is determined from a stress-strain diagram. It is the stress corresponding to the intersection of the stress-strain curve and a line parallel to its straight line portion offset by a specified strain. Offset is usually specified as 0.2 %, i.e., the intersection of the offset line and the 0-stress axis is at 0.2 % strain.

**Yield strength elongation.** Strain corresponding to yield strength of material. It is an indication of ductility.

**Yield value.** Stress in an adhesive joint at which a marked increase in deformation occurs without an increase in load.

**Young's modulus.** Alternate term for modulus of elasticity in tension or compression. Reprinted from *MATERIALS ENGINEERING, June 1967 issue, Reinhold Publishing Corporation, 430 Park Avenue, New York, N. Y. 10022*

# Appendix C

## References

Beer, Ferdinand P. and Russell Johnston. Mechanics of Materials. 2<sup>nd</sup> ed. New York: McGraw-Hill, 1992.

Popov, Egor Paul. Engineering Mechanics of Solids. 2<sup>nd</sup> ed. New Jersey: Prentice-Hall Inc., 1998.

Shames, Irving H., and James M. Pitarresi. Introduction to Solid Mechanics. 3<sup>rd</sup> ed. New Jersey: Prentice-Hall Inc., 2000.

Pytel, Andres and Jaan Kiusalaas. Mechanics of Materials. Pacific Grove, CA: Brooks / Cole, 2003.

Beckwith, T.G, Lienhard, J.H.. and Roy D. Marangoni. Mechanical Measurements. 5<sup>th</sup> ed. New York: Addison-Wesley, 1993.

Dowling, Norman E., Mechanical Behavior of Materials. 2<sup>nd</sup> ed. New Jersey: Prentice-Hall Inc., 1999.

Oberg, Jones, Horton, and Ryffel. Machinery's Handbook. 27<sup>th</sup> ed. New York: Industrial Press Inc., 2004.